

KF Series FA Ball Valves



KF Industries



Superior Fluid Control Products for the Petrochemical and Industrial Markets

A division of **CIRCOR** International, Inc.

Series FA Ball Valves

This high quality two-piece split body trunnion mounted ball valve conforms to API 6D, ASME B16.34 and ASTM specifications. Devlon® seats are standard. All seats are retained in metal holders which are spring-loaded against the ball for low pressure, firesafe sealing.

Series FA valves are offered in:
2" thru 14" class 150 & 300

General Design Features

- Double block and bleed
- Anti blowout stem design
- O-rings plus firesafe packing prevents leakage
- Corrosion resistant low friction bearings
- Inconel wave springs to provide upstream and downstream sealing
- Stainless Steel Sealant injection fittings for emergency stem or seat sealing
- Minimized torque required to open and close valve
- Antistatic grounding between ball, stem/trunnion and body
- Integral topworks direct mounting pad
- 8" & larger valves are equipped with lifting lugs

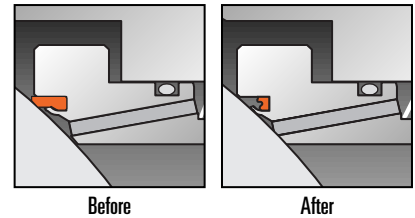

Firesafe Function

In case of fire and seat construction damage, firesafe requirements are accomplished with automatic metal-to-metal positive sealing.

Contents

General Design Features	2	Component Parts • Series FA 2"-6"	8
Additional Design Features	3	Component Parts • Series FA 6"-14"	9
Technical Seating Features, Availability And Maximum Pressure Ratings.	4	Dimensional Data	
Applicable Standards.	5	API 6D & ASME B16.34 Class 150 (in./mm)	10
Assembly Part Number Codes		API 6D & ASME B16.34 Class 300 (in./mm)	11
Series FA Valve Assembly	6	Topworks and Stem Torque (in., mm)	12
Series FA Valve Buttweld End Assembly	7	Pressure Temperature Charts and Flow Data . .	13
		Optional Features	14



Design Features

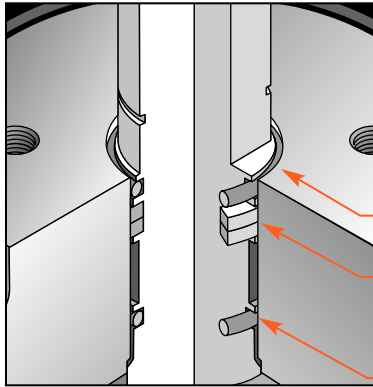

Firesafe Standard Double Seal

2"FP - 12" Bore
Class 150 & 300

Weather Seal

Stem Packing Braided Carbon Rope

Primary Stem Seal

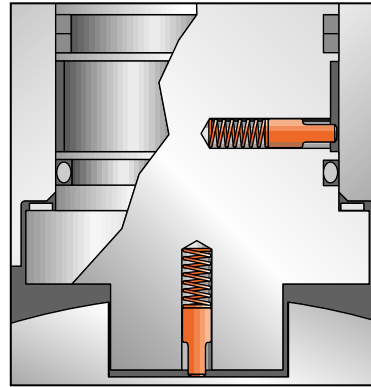

Antistatic Device*

A Stainless Steel grounding plunger between the body/stem and stem/ball permits electrical continuity.

*2" - 4" bore Antistatic accomplished through trunnion bearing.

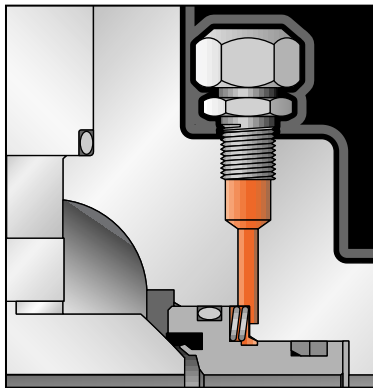

Emergency Seat Seal

Special sealants may be injected into fittings that are located on the adapter flanges to restore sealing integrity if seat sealing surface is damaged.

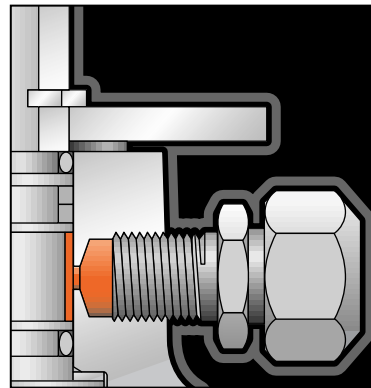

Emergency Sealant Injection System

The Sealant Injection System located on the body can be utilized in case of emergencies, o-ring damage, or if stem leakage occurs.

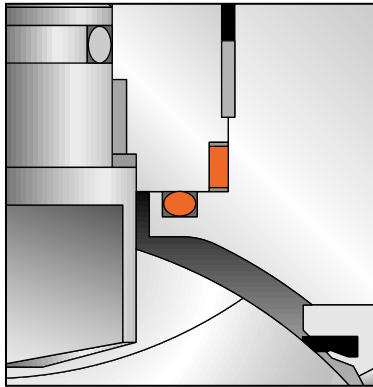

Double Sealed Envelope Connections 2" - 4" Bore

A combination of an o-ring and Firesafe gasket ensures a positive seal.

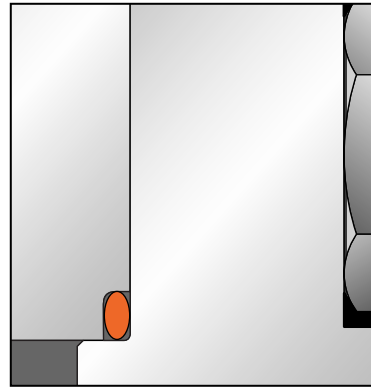

Body/Adapter Seal Connection 6" - 12" Bore

An o-ring on this connection insures a positive seal.

Heavy Duty Bearings

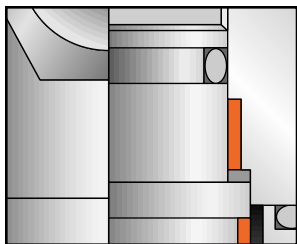

Garloc DU upper stem and lower trunnion, 2" - 4" bore.

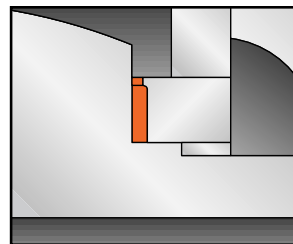
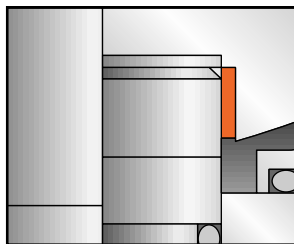

Teflon® and glass liner with 316SS housing integral trunnion with trunnion blocks, 6" - 12" bore.

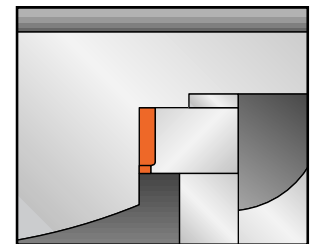

Heavy duty bearings balance the pressure load on the ball by reducing friction between ball and seat resulting in smooth and easy operation of valve.



Technical Seating Features

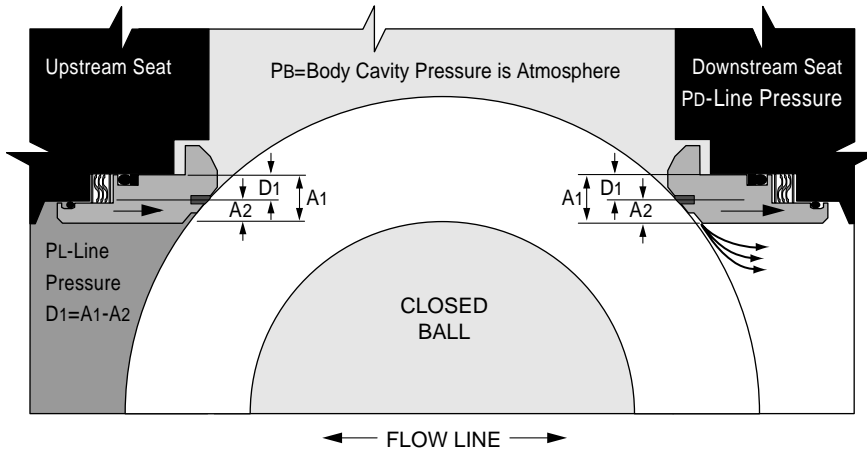

Self Relieving Seat Design

Upstream Seat: The difference in the area (D_1) times the line pressure creates a “piston effect” which forces the seat against the ball surface. Also the springs behind the seat adds the force to the seat which keeps the seat in contact with the ball surface by providing the tight seal.

Downstream Seat: When the body cavity pressure exceeds the spring pressure, automatic pressure relief will occur by relieving the body cavity pressure past the downstream seat. This eliminates the need for the body relief valve.

Double Block and Bleed

The double block and bleed condition is available in all seat design configurations. When the ball is in the closed position the body cavity pressure may be drained down to ‘zero’ by opening the bleed valve and draining the fluid by removing the drain plug. Each seat works independently assuring tight shut off seal against ball on the upstream and downstream side.

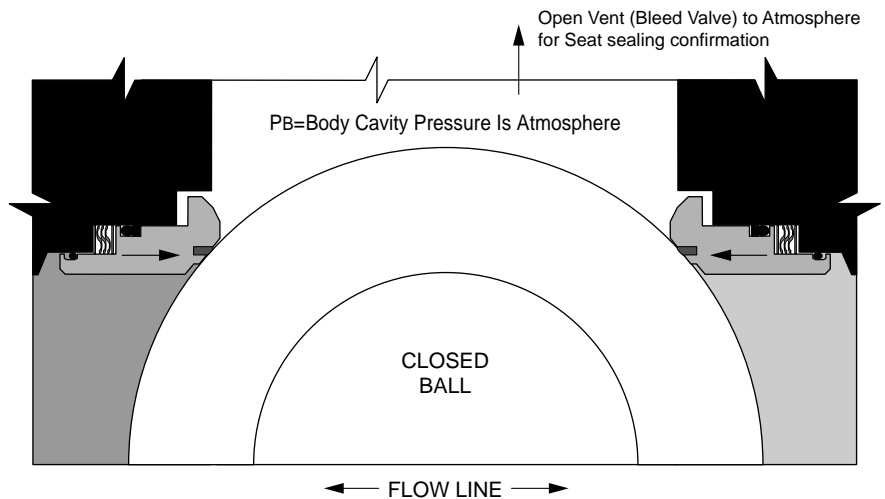

Availability & Maximum Pressure Ratings, ASME B16.34 & API 6D

Class	Size (in.)													
	2 FP	3 RP	3 FP	4 RP	4 FP	6 RP	6 FP	8 RP	8 FP	10 RP	10 FP	12 RP	12 FP	14 RP
150	ASME B16.34	285	285	285	285	285	285	285	285	285	285	285	285	285
	API 6D	275	275	275	275	275	275	275	275	275	275	275	275	275
300	ASME B16.34	740	740	740	740	740	740	740	740	740	740	740	740	740
	API 6D	720	720	720	720	720	720	720	720	720	720	720	720	720



KF Series FA Applicable Standards

The following list contains the most important applicable standards for ball valves. KF valves may be designed,

manufactured and tested in accordance with other international standards on request.*

API-American Petroleum Institute

- Spec. 6D** Specification for pipeline valves.
- Spec. RP6F** Recommended practice for fire testing of valves.
- Spec. 6FA** Specification for fire testing of valves.
- Std. 598** Valve inspection and test.
- Std. 607** Fire test for soft seated quarter-turn valves.

ASME/ANSI-American National Standard

- B 16.5** Steel pipe flanges and flanged fittings.
- B 16.10** Face-to-face and end-to-end dimensions of ferrous valves.
- B 16.25** Butt welding ends.
- B 16.34** Steel valves- Flanged and butt welding ends.
- B 31.3** Chemical plant and petroleum refinery piping
- B 31.4** Liquid petroleum transportation piping systems.
- B 31.8** Gas transmission and distribution piping systems.

British Standard

- BS 1503** Specification for steel forgings for pressure purposes.
- BS 1504** Specification for steel castings for pressure purposes.
- BS 1560** Steel pipe flanges and flanged fittings.
- BS 2080** Face-to-face, center-to-face, end-to-end, and center-to-end dimensions of flanged and butt-welding end steel valves for the petroleum, petrochemical and allied industries.
- BS 4504** Flanges and boltings for pipes, valves and fittings.

British Standard - cont.

- BS 5146** Inspection and test of steel valves for the petroleum, petrochemical and allied industries.
- BS 5351** Steel ball valves for the petroleum, petrochemical and allied industries.
- BS 5750** Quality system.
- BS 6755** Testing of valves.

EC-European Community

- CE Marked** (P.E.D. 97/23/EC, Cat. 3)

ISO-International Organization for Standardization

- ISO 9001:2000** Quality systems-Model for quality assurance in design/development, production, installation and servicing.

MSS-Manufacturers Standardization Society

- SP 6** Standard finishes for contact faces of pipe flanges and connecting- end flanges of valves and fittings.
- SP 25** Standard marking system for valves, fittings, flanges and unions.
- SP 55** Quality standard for steel castings-visual method.

NACE-National Association of Corrosion Engineers

- MR0175** Sulfide stress cracking resistant metallic materials for oil field equipment.

*Charges may apply to non standard design and testing.



Series FA Valve Assembly Part Number Codes

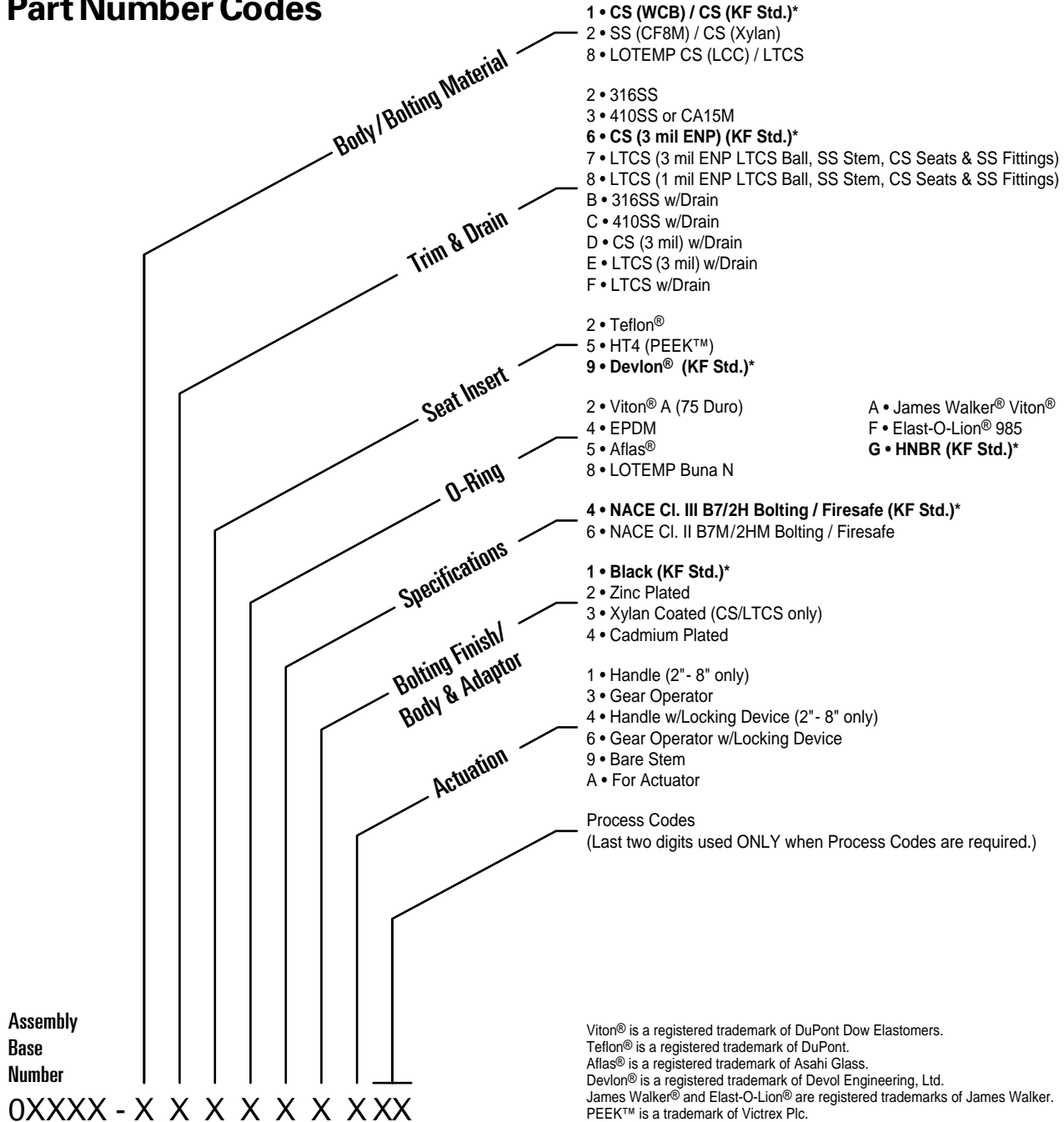

Base number for standard assemblies: OXXXX-XXXXXXXX
Base number for source inspection requirements: OXXXX*XXXXXXXX

Viton® is a registered trademark of DuPont Dow Elastomers.
Teflon® is a registered trademark of DuPont.
Aflas® is a registered trademark of Asahi Glass.
Devlon® is a registered trademark of Devol Engineering, Ltd.
James Walker® and Elast-O-Lion® are registered trademarks of James Walker.
PEEK™ is a trademark of Victrex Plc.

*STANDARD TRIM CONFIGURATION

Assembly Base Numbers, RF

Class	Size (in.)													
	2FP	3RP	3FP	4RP	4FP	6RP	6FP	8RP	8FP	10RP	10FP	12RP	12FP	14RP
150	3758	3759	3760	3761	3762	3763	3764	3765	3766	3767	3768	3769	3770	8018
300	3778	3779	3780	3781	3782	3783	3784	3785	3786	3787	3788	3789	3790	8019



Series FA Valve Butt Weld End Assembly

Part Number Codes

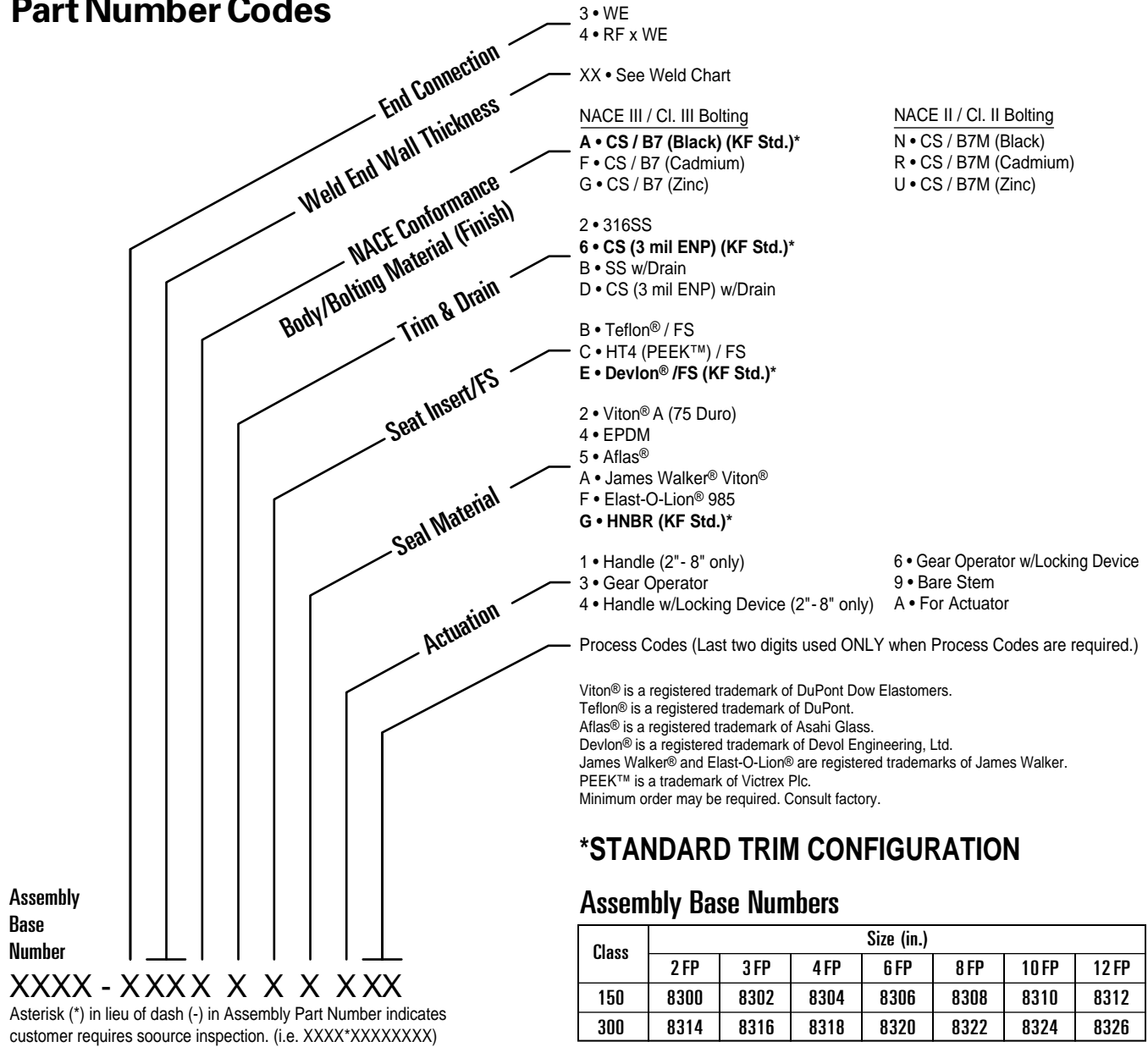

KF Series FA Butt Weld End Schedule Code

Pipe Description	Nominal Pipe Size (in.)/KF Schedule Code													
	2	Code	3	Code	4	Code	6	Code	8	Code	10	Code	12	Code
Outside Dia. (In.)	2.375		3.500		4.500		6.625		8.625		10.750		12.750	
(STD) Standard	—	—	—	—	.237	17	.280	22	.322	28	.365	32	.375	33
Schedule 40	.154	08	.216	14	.237	17	.280	22	.322	28	.365	32	.406	35
Schedule 60	—	—	—	—	—	—	—	—	.406	35	.500	39	.562	42
XS	.218	15	.300	24	.337	30	.432	36	.500	39	.500	39	.500	39
Schedule 80	.218	15	.300	24	.337	30	.432	36	.500	39	.593	43	.687	48
Schedule 120	—	—	—	—	.438	38	.562	42	.718	49	.843	52	1.000	58
Schedule 160	.343	31	.438	38	.531	40	.718	49	.906	55	1.125	62	1.312	68
XXS	.436	37	.600	44	.674	47	.864	53	.875	54	1.000	58	1.000	58

Consult factory for other wall thicknesses.



Series FA • Component Parts, 2" FP - 6" RP

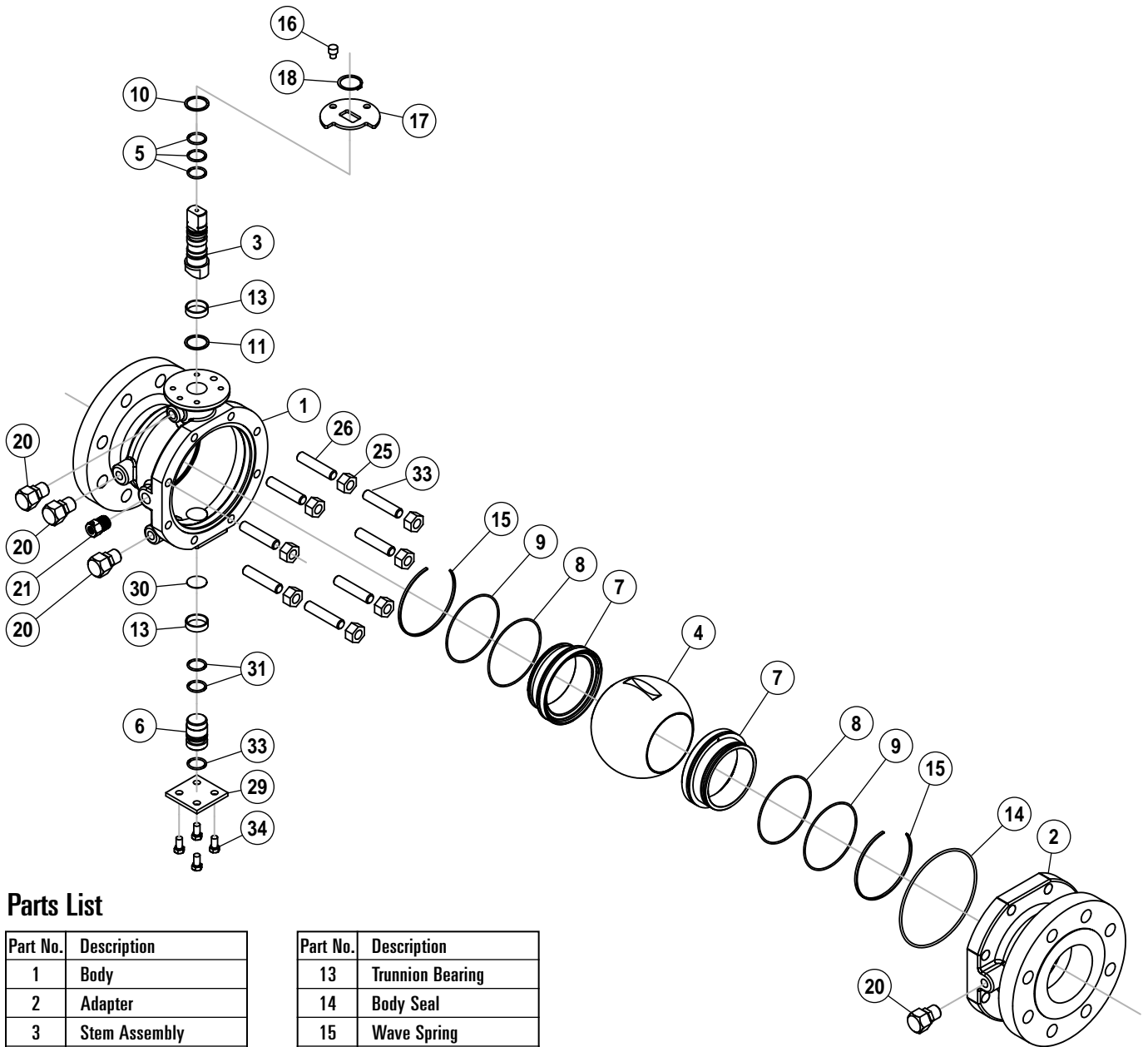

Parts List

Part No.	Description
1	Body
2	Adapter
3	Stem Assembly
4	Ball
5	Stem Seal
7	Seat
8	Seat O-Ring
9	Seat Sub Seal
10	Stem Bearing
11	Thrust Bearing
12	Trunnion Support

Part No.	Description
13	Trunnion Bearing
14	Body Seal
15	Wave Spring
16	Stop Screw
17	Stop Plate
18	Retainer
20	Injection Fitting
21	Bleed Valve
25	Hex Nut
26	Stud



Series FA • Component Parts, 6" FP - 14" RP*

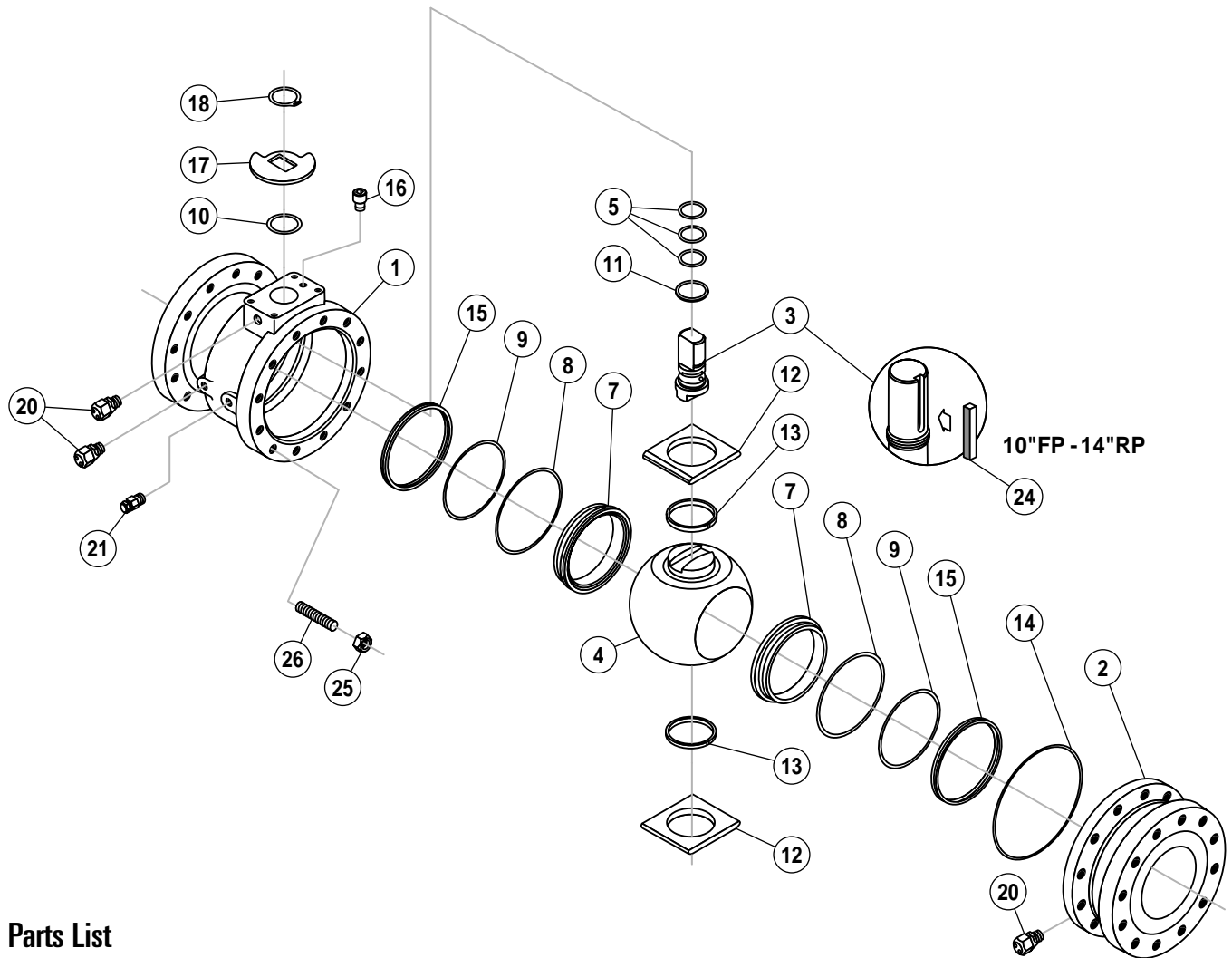

Parts List

Part No.	Description
1	Body
2	Adapter
3	Stem Assembly
4	Ball
5	Stem Seal
7	Seat
8	Seat O-Ring
9	Seat Sub Seal
10	Stem Bearing
11	Thrust Bearing
12	Trunnion Support

Part No.	Description
13	Trunnion Bearing
14	Body Seal
15	Wave Spring
16	Stop Screw
17	Stop Plate
18	Retainer
20	Injection Fitting
21	Bleed Valve
24	Key, 10"FP thru 12"FP only
25	Hex Nut
26	Stud

*14" cl. 150 not shown.



KF Series FA Dimensional Data (in./mm), API 6D & ASME B16.34, Class 150

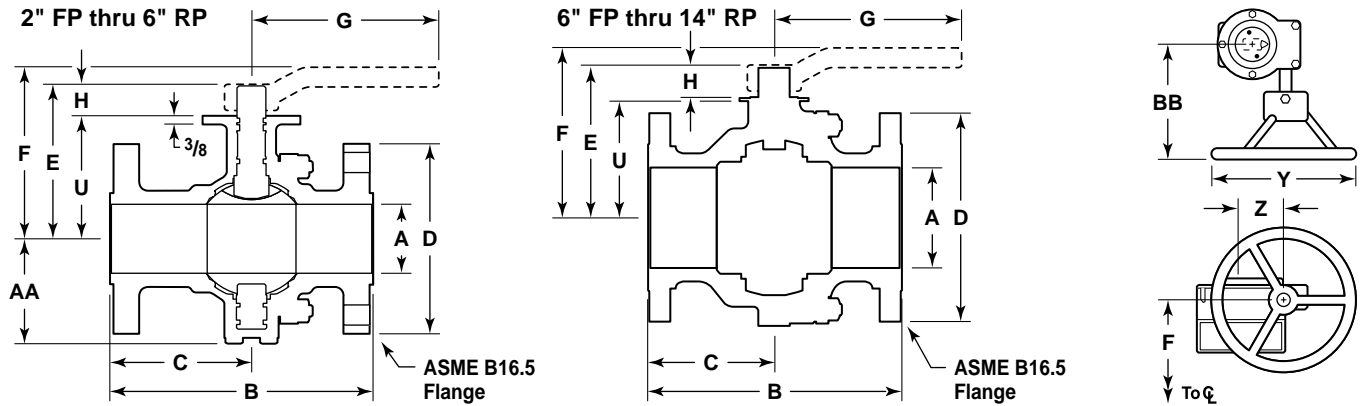

Dimensional Data (in./mm) 2"FP-14"RP

Size (in.)	Dimension (in.)															
	Wt. (lbs.)		A	B	C	D	E	F		G	H	U	Y	Z	AA	BB
	Valve Only	w/Gear Op.						Top of Handle	CL of H/Whl.							
2 x 2	31	43	2	7	3 1/8	6	4 15/16	6 7/8	5	8 1/2	1 1/16	3 7/8	8	2 3/4	3 9/16	7 3/16
3 x 2	33	46	2	8	4	7 1/2	4 15/16	6 7/8	5	8 1/2	1 1/16	3 7/8	8	2 3/4	3 9/16	7 3/16
3 x 3	52	65	3	8	3 7/8	7 1/2	6 5/8	8 1/4	6 1/2	15	1 1/4	5 3/8	8	2 3/4	4 1/2	7 3/16
4 x 3	60	73	3	9	4 1/2	9	6 5/8	8 1/4	6 1/2	15	1 1/4	5 3/8	8	2 3/4	4 1/2	7 3/16
4 x 4	78	91	4	9	4 1/2	9	7 7/16	9	7 5/16	15	1 1/4	6 3/16	8	2 3/4	4 1/2	7 3/16
6 x 4	110	123	4	15 1/2	5 1/4	11	7 7/16	9	7 5/16	15	1 1/4	6 3/16	8	2 3/4	5 1/4	7 3/16
6 x 6	204	234	6	15 1/2	7 3/4	11	9 1/2	10 13/16	9 1/4	48	2 3/32	7	12	2 1/2	5 1/4	9 1/4
8 x 6	271	301	6	18	9	13 1/2	9 1/2	10 13/16	9 1/4	48	2 3/32	7	12	2 1/2	—	9 1/4
8 x 8	365	429	8	18	9	13 1/2	11 9/16	12 19/32	10 3/8	48 5/16	2 3/8	8 3/4	18	3 1/2	—	11 15/16
10 x 8	456	520	8	21	10 1/2	16	11 9/16	12 19/32	10 3/8	48 5/16	2 3/8	8 3/4	18	3 1/2	—	11 15/16
10 x 10	528	605	10	21	10 1/2	16	14 5/16	—	13 3/8	—	3 3/16	11 1/4	24	4 5/8	—	14 5/8
12 x 10	648	725	10	24	12	19	14 5/16	—	13 3/8	—	3 3/16	11 1/4	24	4 5/8	—	14 5/8
12 x 12	794	899	12	24	12	19	15 11/16	—	14 3/4	—	3 3/16	12 5/8	24	4 5/8	—	14 5/8
14 x 12	944	1049	12	27	13 1/2	21	17 11/16	—	16 1/4	—	3 3/16	14 5/8	36	4 5/8	—	17 3/4

Size (in.)	Dimension (mm)															
	Wt. (kg)		A	B	C	D	E	F		G	H	U	Y	Z	AA	BB
	Valve Only	w/Gear Op.						Top of Handle	CL of H/Whl.							
2 x 2	14.1	19.5	50.8	178	79.4	152	125.4	174.6	127	216.9	27.0	98.4	203.2	69.9	90.5	182.6
3 x 2	15.0	20.9	50.8	203	102	191	125.4	174.6	127	216.9	27.0	98.4	203.2	69.9	90.5	182.6
3 x 3	23.6	29.5	76.2	203	98.4	191	168.3	209.6	165	381	31.8	136.3	203.2	69.9	114.3	182.6
4 x 3	27.2	33.1	76.2	229	114.3	229	168.3	209.6	165	381	31.8	136.3	203.2	69.9	114.3	182.6
4 x 4	35.4	41.3	101.6	229	114.3	229	188.9	228.6	185.7	381	31.8	157.2	203.2	69.9	114.3	182.6
6 x 4	49.9	55.8	101.6	394	133.3	279	188.9	228.6	185.7	381	31.8	157.2	203.2	69.9	133.4	182.6
6 x 6	92.5	106.1	152	394	196.8	279	241	274.6	235.0	1219	53.2	177.8	304.8	63.5	133.4	235.0
8 x 6	122.9	136.5	152	457	229	342.9	241	274.6	235.0	1219	53.2	177.8	304.8	63.5	—	235.0
8 x 8	165.6	194.6	203	457	229	342.9	293.7	319.9	263.5	1227	60.3	222.3	457.2	88.9	—	303.2
10 x 8	206.8	235.9	203	533	267	406	293.7	319.9	263.5	1227	60.3	222.3	457.2	88.9	—	303.2
10 x 10	239.5	274.4	254	533	267	406	363.6	—	339.7	—	81.0	285.8	609.6	117.5	—	371.5
12 x 10	293.9	328.9	254	610	305	483	363.6	—	339.7	—	81.0	285.8	609.6	117.5	—	371.5
12 x 12	360.2	407.8	305	610	305	483	398.5	—	374.7	—	81.0	320.7	609.6	117.5	—	371.5
14 x 12	428.2	475.8	305	685.8	342.9	533.4	433.4	—	412.8	—	81.0	371.5	914.4	117.5	—	450.9



KF Series FA Dimensional Data (in./mm), API 6D & ASME B16.34, Class 300

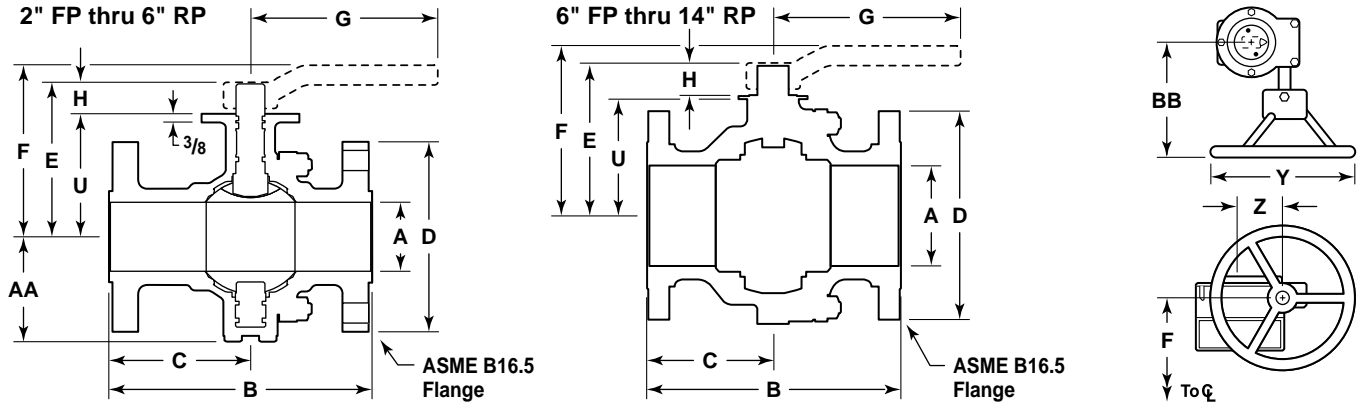

Dimensional Data (in./mm) 2"FP-14"RP

Size (in.)	Dimension (in.)															
	Wt. (lbs.)		A	B	C	D	E	F		G	H	U	Y	Z	AA	BB
	Valve Only	w/Gear Op.						Top of Handle	CL of H/Whl.							
2 x 2	35	48	2	8 1/2	4 1/4	6 1/2	4 15/16	6 7/8	5	8 1/2	1 1/16	3 7/8	8	2 3/4	3 9/16	7 3/16
3 x 2	42	55	2	11 1/8	5 9/16	8 1/4	4 15/16	6 7/8	5	8 1/2	1 1/16	3 7/8	8	2 3/4	3 9/16	7 3/16
3 x 3	63	76	3	11 1/8	6	8 1/4	6 5/8	8 1/4	6 1/2	15	1 1/4	5 3/8	8	2 3/4	4 1/2	7 3/16
4 x 3	83	96	3	12	6	10	6 5/8	8 1/4	6 1/2	15	1 1/4	5 3/8	8	2 3/4	4 1/2	7 3/16
4 x 4	114	127	4	12	6	10	7 7/16	9	7 5/16	15	1 1/4	6 3/16	8	2 3/4	4 1/2	7 3/16
6 x 4	160	173	4	15 7/8	7 15/16	12 1/2	7 7/16	9	7 5/16	15	1 1/4	6 3/16	8	2 3/4	5 1/4	7 3/16
6 x 6	282	312	6	15 7/8	7 15/16	12 1/2	9 1/2	10 13/16	9 1/4	48	2 3/32	7	14	2 1/2	5 1/4	9 3/8
8 x 6	352	382	6	19 3/4	9 7/8	15	9 1/2	10 13/16	9 1/4	48	2 3/32	7	14	2 1/2	—	9 3/8
8 x 8	481	545	8	19 3/4	9 7/8	15	11 9/16	12 19/32	10 3/8	48 5/16	2 3/8	8 3/4	18	3 1/2	—	11 15/16
10 x 8	597	661	8	22 3/8	11 3/16	17 1/2	11 9/16	12 19/32	10 3/8	48 5/16	2 3/8	8 3/4	18	3 1/2	—	11 15/16
10 x 10	735	840	10	22 3/8	11 3/16	17 1/2	14 5/16	—	13 3/8	—	3 3/16	11 1/4	24	4 5/8	—	14 5/8
12 x 10	904	1009	10	25 1/2	12 3/4	20 1/2	14 5/16	—	13 3/8	—	3 3/16	11 1/4	24	4 5/8	—	14 5/8
12 x 12	1083	1188	12	25 1/2	12 3/4	20 1/2	15 11/16	—	14 3/4	—	3 3/16	12 5/8	24	4 5/8	—	14 5/8
14 x 12	1233	1385	12	30	15	23	15 11/16	—	14 3/4	—	3 3/16	12 5/8	24	4 5/8	—	14 5/8

Size (in.)	Dimension (mm)															
	Wt. (kg)		A	B	C	D	E	F		G	H	U	Y	Z	AA	BB
	Valve Only	w/Gear Op.						Top of Handle	CL of H/Whl.							
2 x 2	15.9	21.8	50.8	215.9	108.0	165.1	125.4	174.6	127	216.9	27.0	98.4	203.2	69.9	90.5	182.6
3 x 2	19.1	24.9	50.8	282.6	141.3	209.6	125.4	174.6	127	216.9	27.0	98.4	203.2	69.9	90.5	182.6
3 x 3	28.6	34.5	76.2	282.6	152.4	209.6	168.3	209.6	165	381	31.8	136.3	203.2	69.9	114.3	182.6
4 x 3	37.6	43.5	76.2	304.8	152.4	254	168.3	209.6	165	381	31.8	136.3	203.2	69.9	114.3	182.6
4 x 4	51.7	57.6	101.6	304.8	152.4	254	188.9	228.6	185.7	381	31.8	157.2	203.2	69.9	114.3	182.6
6 x 4	72.6	78.5	101.6	403.2	201.6	317.5	188.9	228.6	185.7	381	31.8	157.2	203.2	69.9	133.4	182.6
6 x 6	127.9	141.5	152	403.2	201.6	317.5	241	274.6	235.0	1219	53.2	177.8	355.6	63.5	133.4	238.1
8 x 6	159.7	173.3	152	501.7	250.8	381	241	274.6	235.0	1219	53.2	177.8	355.6	63.5	—	238.1
8 x 8	218.2	247.2	203	501.7	250.8	381	293.7	319.9	263.5	1227	60.3	222.3	457.2	88.9	—	303.2
10 x 8	270.8	299.8	203	568.3	281.0	444.5	293.7	319.9	263.5	1227	60.3	222.3	457.2	88.9	—	303.2
10 x 10	333.4	381.0	254	568.3	281.0	444.5	363.6	—	339.7	—	81.0	285.8	609.6	117.5	—	371.5
12 x 10	410.0	457.7	254	647.7	323.9	520.7	363.6	—	339.7	—	81.0	285.8	609.6	117.5	—	371.5
12 x 12	491.2	538.9	305	647.7	323.9	520.7	398.5	—	374.7	—	81.0	320.7	609.6	117.5	—	371.5
14 x 12	559.3	628.2	305	762	381	584.2	398.5	—	374.7	—	81.0	320.7	609.6	117.5	—	371.5



Topworks & Stem Torque (in./mm)

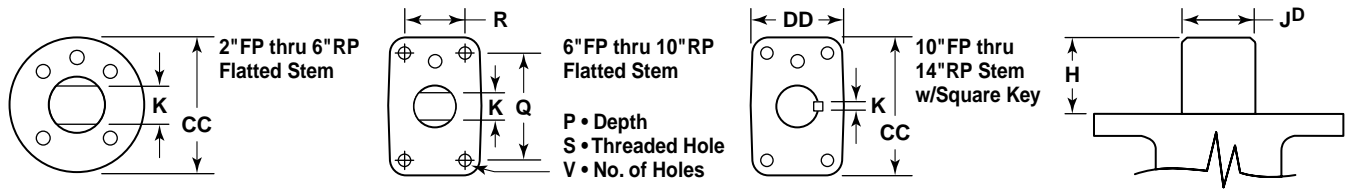

Valve Size (in.)	Dimension (in.)											Max. Stem Shear Torque Ft.-Lbs.	Break* Torque In.-Lbs.	Torque Expression See Notes 1, 2, 3 Below Chart
	Pressure Class	H	Jd Stem Dia.	K	P Hole Depth	Q	R	S Threaded Hole	V No. of Holes	CC	DD			
2	150	1 1/16	.873/.867	.558/.554	—	—	—	—	4	4 1/8	—	1634	351	.624*P + 1728
2	300	1 1/16	.873/.867	.558/.554	—	—	—	—	8	4 1/8	—	1634	632	
3	150	1 1/4	1.246/1.240	.748/.744	—	—	—	—	4	4 1/8	—	4297	768	1.29*P + 400
3	300	1 1/4	1.246/1.240	.748/.744	—	—	—	—	8	4 1/8	—	4297	1355	
4	150	1 1/4	1.246/1.240	.748/.744	—	—	—	—	8	4 1/8	—	4297	1178	1.44*P + 768
4	300	1 1/4	1.246/1.240	.748/.744	—	—	—	—	8	4 1/8	—	4297	1834	
6	150	2 3/32	1.999/1.995	1.249/1.245	3/4	3 3/8	2	3/8 - 16	8	5 1/8	3 1/8	18,959	4968	4.8*P + 3600
6	300	2 3/32	1.999/1.995	1.249/1.245	3/4	4 1/2	2 3/8	1/2 - 13	12	5 5/8	3 1/2	18,959	7152	
8	150	2 3/8	2.499/2.495	1.749/1.745	1	4 5/8	2 7/8	1/2 - 13	8	6 1/4	4 1/8	46,657	8714	11.04*P + 5568
8	300	2 3/8	2.499/2.495	1.749/1.745	1	4 5/8	2 7/8	1/2 - 13	12	6 1/4	4 1/8	46,657	13,738	
10	150	3 3/16	2.874/2.871	3/4 Sq.	1 1/8	6	3 1/2	5/8 - 11	12	7 1/2	5	68,121	15,157	19.07*P + 9722
10	300	3 3/16	2.874/2.871	3/4 Sq.	1 1/8	6	3 1/2	5/8 - 11	16	7 1/2	5	68,121	23,834	
12	150	3 3/16	2.874/2.871	3/4 Sq.	1 1/8	6	3 1/2	5/8 - 11	12	7 1/2	5	68,121	20,811	28.90*P + 12,574
12	300	3 3/16	2.874/2.871	3/4 Sq.	1 1/8	6	3 1/2	5/8 - 11	16	7 1/2	5	68,121	33,960	

*Torque listed is calculated for "clean wet service", use 1.22 multiplier to this to calculate for "dry gas service".

Note: (1) Torques are actual and based on maximum differential and low temperature service, without safety factors.
(2) KF recommends adding a 25% safety factor for pneumatic and 50% for electric actuators
(3) Differential pressure "P" in torque expressions is in PSI.

Pressure ratings according to API 6D:
Class 150 P = 285 psi
Class 300 P = 740 psi

Valve Size (in.)	Dimension (mm)											Max. Stem Shear Torque Nm	Break* Torque Nm	Torque Expression See Notes 1, 2, 3 Below Chart
	Pressure Class	H	Jd Stem Dia.	K	P Hole Depth	Q	R	S Threaded Hole	V No. of Holes	CC	DD			
2	150	27.0	22.17/22.02	14.17/14.07	—	—	—	—	4	104.8	—	2215	39.06	10.247*P + 19.524
2	300	27.0	22.17/22.02	14.17/14.07	—	—	—	—	8	104.8	—	2215	71.41	
3	150	31.8	31.65/31.50	19.00/18.90	—	—	—	—	4	104.8	—	5826	86.78	21.60*P + 45.19
3	300	31.8	31.65/31.50	19.00/18.90	—	—	—	—	8	104.8	—	5826	153.11	
4	150	31.8	31.65/31.50	19.00/18.90	—	—	—	—	8	104.8	—	5826	133.11	23.60*P + 86.77
4	300	31.8	31.65/31.50	19.00/18.90	—	—	—	—	8	104.8	—	5826	207.23	
6	150	53.2	50.77/50.67	31.72/31.62	19.1	85.7	50.8	3/8 - 16	8	130.2	79.4	25,705	561.36	78.60*P + 406.75
6	300	53.2	50.77/50.67	31.72/31.62	19.1	114.3	60.3	1/2 - 13	12	142.9	88.9	25,705	808.14	
8	150	60.3	63.47/63.37	44.42/44.32	25.4	117.5	73.0	1/2 - 13	8	158.8	104.8	63,258	984.63	180.91*P + 629.10
8	300	60.3	63.47/63.37	44.42/44.32	25.4	117.5	73.0	1/2 - 13	12	158.8	104.8	63,258	1552.32	
10	150	81.0	73.00/72.92	19.1 Sq.	28.6	152.4	88.9	5/8 - 11	12	190.5	127	92,360	1712.66	312.50*P + 1098.44
10	300	81.0	73.00/72.92	19.1 Sq.	28.6	152.4	88.9	5/8 - 11	16	190.5	127	92,360	2692.88	
12	150	81.0	73.00/72.92	19.1 Sq.	28.6	152.4	88.9	5/8 - 11	12	190.5	127	92,360	2351.33	473.58*P + 1420.62
12	300	81.0	73.00/72.92	19.1 Sq.	28.6	152.4	88.9	5/8 - 11	16	190.5	127	92,360	3836.96	

*Torque listed is calculated for "clean wet service", use 1.22 multiplier to this to calculate for "dry gas service".

Note: (1) Torques are actual and based on maximum differential and low temperature service, without safety factors.
(2) KF recommends adding a 25% safety factor for pneumatic and 50% for electric actuators
(3) Differential pressure "P" in torque expressions is in Mpa.

Pressure ratings according to API 6D:
Class 150 P = 1.965 Mpa
Class 300 P = 5.103 Mpa



KF Series FA Pressure Temperature And Flow Data

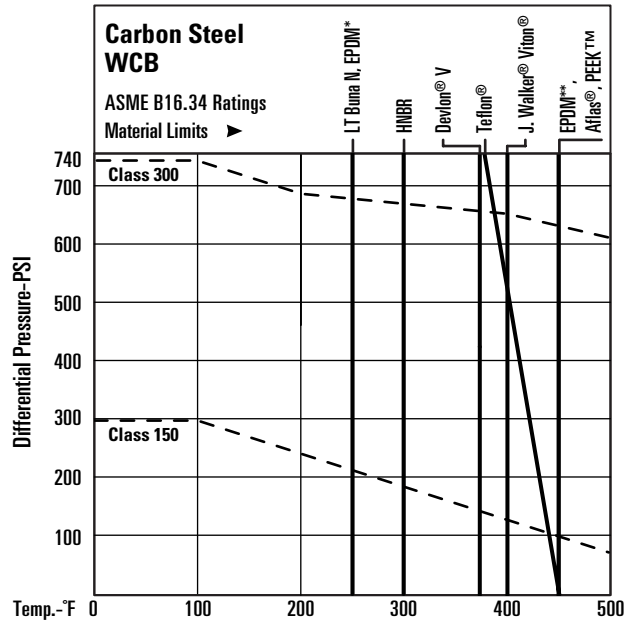
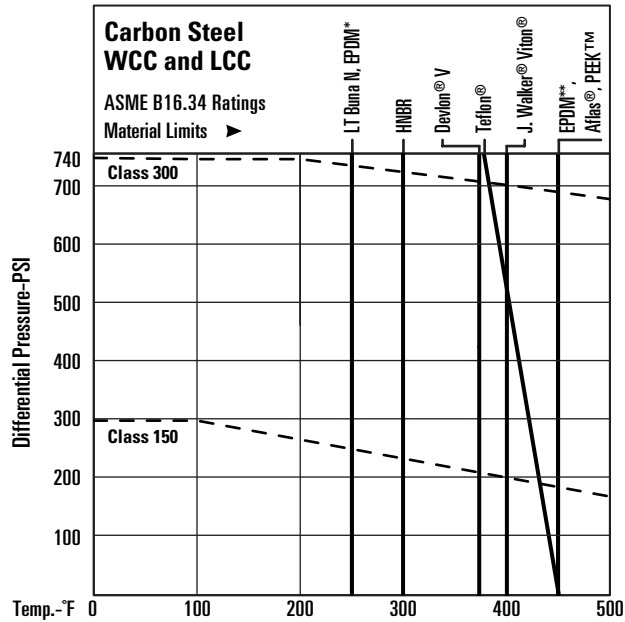

Pressure Temperature Chart Notes: Consult factory for service above 325°F.
* For chemical service. ** For water and steam service only.

Pressure Temperature Chart Notes: Consult factory for service above 325°F.
* For chemical service. ** For water and steam service only.

Low Temperature Limits

Body Material	°F	°C
WCC	-20°	-28.9
LCC	-50°	-45.6
WCB	-20°	-28.9
CF8M	-50°	-45.6

Seat Material	°F	°C
Devlon® V	-50°	-45.6
Teflon®	-50°	-45.6
HT4 (PEEK™)	-50°	-45.6

Seal Material	°F	°C
Atlas®	+32°	0
Buna N	-30°	-34.4
Low Temp Buna N	-50°	-45.6
Viton®	-15°	26.1

Seal Material	°F	°C
James Walker® Viton®	+10°	-12.2
HNBR	-40°	-40
EPDM	-50°	-45.6

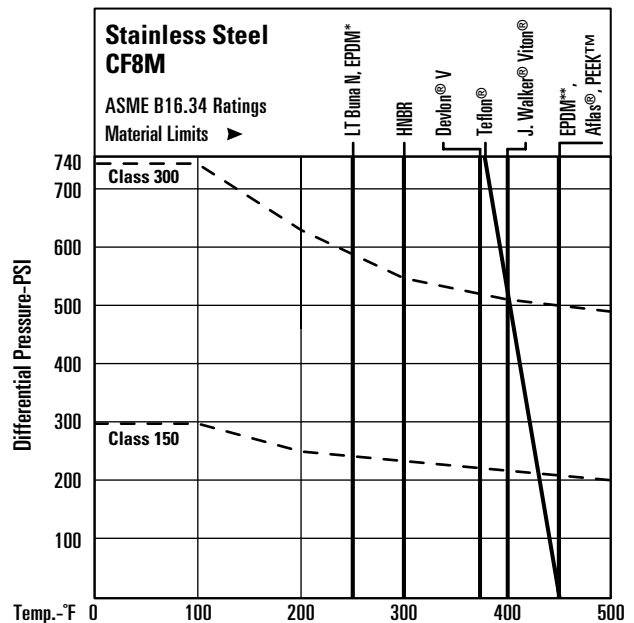

Flow Coefficient (C_v)

Class	Size (in.)													
	2 FP	3 RP	3 FP	4 RP	4 FP	6 RP	6 FP	8 RP	8 FP	10 RP	10 FP	12 RP	12 FP	14 RP
150	420	225	1050	600	2000	910	5470	2500	10,750	5000	17,775	8400	26,750	14,125
300	420	225	1050	600	2000	910	5100	2400	10,300	4825	16,300	8200	26,000	14,075

Method of Calculating Flow

The Flow Coefficient "C_v" of a valve is the flow rate of water (gallons/minute @ 60°F) through a fully opened valve, with a pressure drop of 1 psi across the valve. To find the flow of a liquid or gas through a valve from the C_v, use the following formulas:

Liquid Flow

Q_L = flow rate of liquid (gal./min.)

ΔP = differential pressure across the valve (psi)

G = Specific gravity of liquid (for water, G=1)

$$Q_L = C_v \sqrt{\frac{\Delta P}{G}}$$

Gas Flow

Q_G = flow rate of gas (CFH at STP)

P₂ = outlet pressure (psia)

g = Specific gravity of gas (for air, g=1.000)

$$Q_G = 61 C_v \sqrt{\frac{P_2 \Delta P}{g}} \quad \left\{ \frac{\Delta P}{P_2} < 1.0 \right\}$$

For non-critical flow



KF Series FA Optional Features

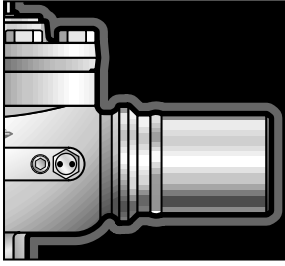

Pups

Butt Weld valves may be supplied with transition pieces (PUPS) to avoid any risk of seat and seal damage during welding and post weld heat treatment operations. Length of pups and type of pipe and grade to be specified by customer.

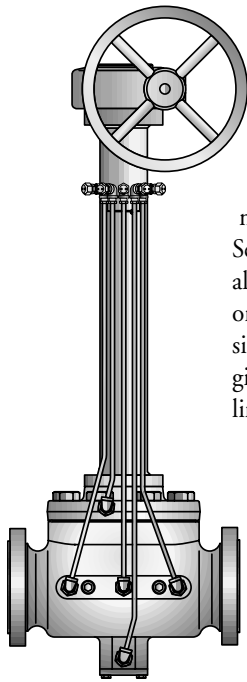

Extensions

KF Series FA ball valves are available for below ground or buried service with fully operational extensions to meet your specifications. Body Bleed and Sealant Injection functions are maintained along with total valve control by manual or powered actuators. Extension dimensions for Gear Operator or Actuator are given with reference from the valve center line to the center of hand wheel.

Actuators

The bonnet design on KF Series FA Ball Valves permits easy adaptation to mount manual, electric, hydraulic, or pneumatic actuators.

Tar Set Coating

KF Series FA ball valves can be Tar Set coated for added corrosion protection to meet specific application requirements. Tar Set coating is available upon request. Ask your KF Industries representative for more information on this special coating process.

Metal Seated Ball Valves

KF Series FA Metal Seated ball valves have been designed to provide a reliable, efficient and safe method to handle services where high temperatures and/or the presence of solid particles in the fluid make it impossible, or not recommended, to use soft seated ball valves.

Sub-Sea Options: Sub-Sea valves are optionally available with CoalTar Epoxy Coating (18 to 20 mils), Xylan Coated Bolting and Sub-Sea Gear Operators.

Installation

Flange Ends (RF):

- Series FA Ball Valves may be mounted in either vertical or horizontal piping systems. The stem may be positioned vertically or horizontally.
- Mating flanges must be correctly aligned. Alignment includes bolt hole placement, parallelism, and perpendicularity.
- Flange studs or bolting must be correct size and properly tightened.
- Properly constructed piping systems do not cause undue stress in valve assemblies. Valves are not intended to make up for insufficient pipe tolerances.

Weld Ends (WE):

- Keep ball in open position prior to installation/welding of KF Series FA Weld End Ball Valve.
- Place the valve in position by aligning Weld Ends to the pipe. Prior to welding it is imperative that all welding surfaces be clean from contamination such as dirt, dust and grease which may affect weld performance.

Caution: During the welding process, valve body temperatures should be monitored around the circumference at a location in line with the sealant injection fittings. The temperatures at this plane should be checked with Temperature Stick or other reliable temperature indicator and not allowed to exceed 300°F. This precaution is necessary to assure that non-metallic seals do not suffer heat damage.

- Tack weld valve in position and check for proper alignment.
- Finish weld following proper weld procedure for material grade and condition, and the above Caution.



Notes



Worldwide Sales Offices



KF Industries and its sister companies in the CIRCOR Energy Products Group reach into every corner of the globe serving the oil & gas and industrial marketplace.

Supplying an extensive range of product offerings through a worldwide network of manufacturer representatives and distributors, KF Industries is the right choice for all your flow control needs.

World Headquarters

KF Industries, Inc.
1500 S.E. 89th Street
P. O. Box 95249
Oklahoma City, OK 73143-5249 USA
Phone: (405) 631-1533
Fax: (405) 631-5034
E-mail: kfinfo@kfvalves.com
www.kfvalves.com

US Industrial

KF Contromatics Industrial Products
1500 S.E. 89th Street
P. O. Box 95249
Oklahoma City, OK 73143-5249 USA
Phone: (405) 631-1533
Fax: (405) 631-5034
E-mail: controinfo@kfvalves.com
www.kfvalves.com

Canada

KF Industries, Inc., Canada
9430-39th Avenue, Edmonton
Alberta, Canada T6E 5T9
Phone: (780) 463-8633
Fax: (780) 461-1588
E-mail: kfinfo@kfcanada.com
www.kfvalves.com



KF Industries

A division of **CIRCOR** International, Inc.

Licensed for Manufacture
in accordance with API 6A
& 6D and Firetest
to API 6FA and 607



Registered to the ISO 9001
Quality System Standard,
accredited by U.K., Dutch
and German qualifying
authorities.



www.kfvalves.com • E-mail: kfinfo@kfvalves.com • www.circor.com

©2005 KF Industries, Inc. • KF-FA-Aug-05-HP • Litho USA • KF reserves the right to change designs, materials or specifications without notice or without obligation to furnish or install such changes on products previously or subsequently sold. • KF Industries, Inc. is a division of CIRCOR International, Inc. • Viton® is a registered trademark of DuPont Dow Elastomers. Teflon® is a registered trademark of DuPont. • Atlas® is a registered trademark of Asahi Glass. • Devlon® is a registered trademark of Devol Engineering, Ltd. • James Walker® and Elast-O-Lion® are registered trademarks of James Walker. • PEEK™ is a trademark of Victrex Plc.