

Valves for corrosive applications

Series 132000

Index

- 1 Using Flowserve valves and actuators correctly
- 2 Transport and storage
- 3 Installation
- 4 Intended use
- 5 Installation
- 6 Pressure test pipe section
- 7 Normal operation and maintenance
- 8 Trouble-shooting
- 9 Product description
- 10 Bonnet
- 11 Plug and seat
- 12 Bellows seal
- 13 Stem
- 14 Packing
- 15 Test connection
- 16 Quick check
- 17 Maintenance
- 18 Remove actuator from valve
- 19 Install actuator on valve
- 20 Disassemble valve
- 21 Assemble valve
- 22 Trouble-shooting chart

1.2 Terms concerning safety

The safety terms **DANGER**, **WARNING**, **CAUTION** and **NOTE** are used in these instructions to highlight particular dangers and/or to provide additional information on aspects that may not be readily apparent.



DANGER: indicates that death, severe personal injury and/or substantial property damage will occur if proper precautions are not taken.



WARNING: indicates that death, severe personal injury and/or substantial property damage can occur if proper precautions are not taken.



CAUTION: indicates that minor personal injury and/or property damage can occur if proper precautions are not taken.



NOTE: indicates and provides additional technical information, which may not be very obvious even to qualified personnel. Compliance with other, not particularly emphasised notes, with regard to transport, assembly, operation and maintenance and with regard to technical documentation (e.g. in the operating instruction, product documentation or on the product itself) is essential, in order to avoid faults, which in themselves might directly or indirectly cause severe personal injury or property damage.

1.3 Safety Notes for Operator

The manufacturer is not responsible for the following and it is therefore necessary to ensure the following when using FLOWSERVE control valves:

1.3.1 Use valve as intended (Section 1)



DANGER: Never operate a control valve whose approved pressure/temperature range according to the applicable documentation for the valve series is not sufficient for the operating conditions. Moreover, it must be ensured that the valve is approved for the operating medium:

1 USING KÄMMER VALVES AND ACTUATORS CORRECTLY

1.1 Use

FLOWSERVE control valves and actuators are intended exclusively for control of mediums in an approved pressure and temperature range after installation in a piping system and connection of the actuator to the control system.

The permissible pressure and temperature limits are defined in the operating instructions for the individual valve series.



WARNING: Protection against incorrect use of control valve:

In particular, it is necessary to ensure that the selected coating on the valve parts in contact with the medium are suitable for the mediums, pressures and temperatures encountered. The manufacturer is not responsible for damage to the valve resulting from corrosive mediums.

Failure to observe these precautions can pose a danger for the use and cause damage to the piping system.

- 1.3.2 The piping system and control system must be installed properly and checked regularly. The wall thicknesses of the FLOWSERVE control valves correspond to the standards and regulations for the pressure stage requirements of the piping system in question.
- 1.3.3 The valves must be connected properly to this system.
- 1.3.4 The usual flow rates in continuous operation are not exceeded in this piping system and abnormal operating conditions such as vibration, water hammer, cavitation and excessive quantities of solids in the medium – particularly abrasive solids – must be clarified with the manufacturer.



WARNING: At temperatures $> +50\text{ }^{\circ}\text{C}$ and $< -20\text{ }^{\circ}\text{C}$, it is necessary to provide for protection against touching including the piping connections.

1.4 Particular dangers



DANGER: The valve stem is sealed with a packing gland. Before loosening or unscrewing the packing nut, ensure that the pressure in the pipeline is completely relieved so that the medium cannot escape through the packing.

Observe the usual safety precautions for hazardous medium – particularly protective clothing – when working on the valves.



DANGER: On valves with a bellows seal also ensure that the bellows does not leak by using a test connection, if present, before removing the packing gland nut.



DANGER: Before removing the valve from the pipeline, ensure that the pressure in the pipeline is completely relieved so that the medium does not escape uncontrolled from the line.



WARNING: .If it is necessary to remove a valve from the pipeline, medium can escape from the line or from the valves. In the case of mediums which pose a health danger or other danger, ensure that the pipeline is completely purged before removing the valve. Observe caution with residues flowing out of the line or remaining in the dead chambers of the valves. In the case of dangerous mediums, observe the usual safety precautions – particularly protective clothing.



WARNING: Disconnect or loosen the fasteners – particularly between bonnet and housing – only after the valve has been removed. When reinstalling, tighten the bolts as specified in these maintenance instructions using a torque wrench.

2 TRANSPORT AND STORAGE

Handle, transport and store FLOWSERVE control valves carefully.

- 2.1 Store the valve in its protective packaging and/or with the protective caps on the connection ends. Valves heavier than approx. 10 kg should be stored and transported on a pallet (or similarly supported, where applicable also on the installation site).



WARNING: Do not place unpackaged valves on dirty surfaces with the flange sealing surfaces. Hard and/or sharp particles can damage the plastic lining.

- 2.2 During storage before installation, the valves should be stored in a closed room as a rule and protected against damaging influences such as dirt or moisture.

- 2.3 Large valves can be picked up using hoisting belts on the yoke stems / eyes or - if present – on the supporting shackles provided for this purpose. If hoisting belts are used for unpacking, connect them so that the outer piping and attached parts are not damaged.



WARNING: If hoisting belts are used, the center of gravity of the valve can be higher than the connection point. In such cases, secure the valve against turning or support it to prevent injury or property damage.

In the event of transport damage, please contact your FLOWSERVE representative immediately.

3 INSTALLATION

3.1 General

The same instructions apply for installing FLOWSERVE control valves in a pipeline as for connecting pipes and similar piping elements with plastic liner materials. For control valves, the following instructions apply in addition. Observe Section 3 for transport at the installation site.



WARNING: Handle valves with particular care and observe instructions for flange connections.



NOTE: As a rule, additional flange seals are not required.

The counterflanges must have smooth sealing surfaces in all cases, e.g. Form C, Form D or Form E according to Standard DIN 2526 or Form B1 or B2 according to EN 1092-1 or stock finish according to ANSI B16.5. Other flange forms must be coordinated with the manufacturer.

In addition, observe the following for actuators:



WARNING: *Never subject actuators to external loads; this can damage the valve – actuators are not step ladders -*



WARNING: *Heavy actuators must be supported in a suitable manner if it is possible that their installation situation would exert an impermissible bending force on the valve.*

4 INTENDED USE

The series 132000 valves from Flowserve Essen GmbH can be installed in all areas endangered by gas explosion, because they do not have any potential ignition sources. The valves can be used for shutting off the flow of non-combustible gaseous mediums and combustible gaseous and fluid mediums far below the maximum explosion limit. Inside the valve the atmospheric range is not reached under the conditions (see table below); here Directive 95/9/EC is not applicable. Please note that certain (non-conductive) mediums at certain flow rates can result in a potential (static charge), which is subject to the operating conditions and therefore is the responsibility of the operator.

Version	Packing	Seat Ring
Standard	PTFE Compound	PTFE Compound

4.1 Description of Unit

The valve is a lined control valve. The housing consists of cast iron and the lining and gaskets are of elastomer material.

The compatibility of the materials used with the surrounding mediums must be observed in particular by the operator.

4.2 Evaluation

Conformance with EN 13463, Parts 1 through 8 (non-electrical explosion protection)

The fittings fulfill the following requirements.

4.2.1 All exposed parts were subjected to the impact and environmental stress tests in conformance with EN 13463-1 by the manufacturer and satisfy the requirements.

4.2.2 The valve body for the valves consists of cast iron. Formation of sparks resulting from the effect of exterior impact is excluded under normal conditions.

5 INSTALLATION



WARNING: Plastic liners on the valves require particular protection before/during installation; therefore:



CAUTION: Transport valve to installation site in protective package if available. If flange covers are present, remove them only immediately before installation.

5.1 Check valve for transport damage. Do not install damaged valves.

Ensure that only valves are installed whose pressure class, type of connection and connection dimensions satisfy the installation conditions. See Markings and Valve specifications.



DANGER: Do not install valves whose approved pressure and temperature range is not sufficient for the operating conditions. The limits for use are marked on the valves. Moreover, use only valves suitable for the operating medium in question.

Failure to observe these precautions can pose a danger for the user and cause damage to the piping system.

5.2 The actuator must correspond to the intended connections and control data.

5.3 The connection flanges must be inline with the valve connections and parallel. **Connection flanges which are not parallel can damage the plastic liner during installation!**

5.4 Before installing, thoroughly clean the valve and the pipeline to remove any contamination, particularly hard foreign particles.

5.5 In particular, it is necessary to ensure that the sealing surfaces on the flange connection are free of all contamination when installing.

5.6 When inserting the valve into a pipeline already installed, the distance between the ends of the pipeline must be sufficient to prevent damage to any of the sealing surfaces.



WARNING: Tighten all flange connections to the torques specified in Tables 1a or 1b. When using torque wrenches, ensure that these torques are reached, however not exceeded.

The values in the table apply for flanges according to EN1092, PN10/16 for a maximum operating pressure of 10 bar. Values for other flanges can be obtained from the manufacturer.

5.7 Valves are to be installed in the appropriate flow direction. The flow direction is indicated by an arrow on the valve.

5.8 Observe the appropriate instructions for connecting the actuator to the valve. Control valves are equipped with a positioner. The connections for air supply and signals are marked clearly (see also applicable operating instructions for the positioner). The maximum air supply is specified on the name plate. If the air supply exceeds the pressure specified on the rating plate, a pressure reduction station is required. If no instrument air is available, install an air filter in the air supply line if required.

5.9 After completion of installation, perform a function test with the control signals: The valve should open and close properly corresponding to the control commands. Always eliminate any recognizable malfunctions before startup. See also applicable sections in maintenance regulations for this valve series.



DANGER: Improperly executed control commands can pose a danger for life and limb and damage to the piping system and/or the valve.

Table 1a: Tightening torques for flange connections, flanges EN1092 (DIN)

DN [mm]	15	20	25	40	50	80	100
M _A [Nm]	10	18	25	50	65	55	65

Table 1b: Tightening torques for flange connections, flanges EN1759 (ANSI)

NW [inch]	1/2"	3/4"	1"	1 1/2"	2"	3"	4"
M _A [Nm]	8	11	15	26	60	100	76

6 PRESSURE TESTING PIPING SECTION

The valve has already been pressure-tested by the manufacturer. When pressure testing a section of the pipeline with valves installed, observe the following:

- 6.1 First thoroughly flush newly installed piping systems to remove all foreign objects.
- 6.2 Valve opened: The test pressure should not exceed the value of 1.5 x PN (according to nameplate):
- 6.3 Valve closed: The test pressure should not exceed the value 1.1 x PN (according to nameplate).
If a leak occurs on the valve, observe Section 8 "Troubleshooting".



CAUTION: *If the flange connection with plastic liner leaks:*

First retighten flange connection to torque specified in Table 1a or 1b in Section 5.6 (installation).

If the flange connection is still leaks:

Loosen flange connection. Check the flange connection to ensure that it is smooth and parallel.

Check the sealing surfaces on both flanges: When the inner lining is damaged, replace valve and/or counterflange.

7 NORMAL OPERATION AND MAINTENANCE

These installation, operating and maintenance instructions cannot contain all detailed information on all possible versions for reasons of clarity and, in particular, cannot take into consideration all imaginable cases for setup, operation and maintenance. Therefore, only primarily instructions are contained, which are required for the intended use in industrial applications. If anything is not clear, particularly if any detailed information on the specific product is missing, clarify as required with the responsible FLOWSERVE representative.

8 TROUBLESHOOTING

When troubleshooting or during general maintenance, always observe Section 1 "Safety precautions".



DANGER: *If a valve contaminated with dangerous substances has to be removed from the system or pipeline, decontaminate it properly before performing further maintenance work.*

9 PRODUCT DESCRIPTION

- 9.1 Housing
The body material is made of GGG40.3 (standard), other body materials are also available from the manufacturer on request. For valve bodies with plastic liners: See Table 2b for coating materials.

The liner thickness is at least 5 mm for DN25 and higher and 3.5 mm for DN15 and DN20.

Table 2a: Body specifications

Body material	0.7043 (GGG40.3)
Pressure class	PN16
End connections (flanged)	DIN PN 16 ANSI Class 150
Liner thickness	4 – 6 mm

Table 2b: Liner materials

PFA	Perfluoralkoxypolymer (Standard)
PFA conductive	Perfluoralkoxypolymer, electrically conductive
PVDF	Polyvinilidenfluoride
ETFE	Ethylene Tetrafluorethylene – copolymer (Tefzel®)
FEP	Tetrafluorethylene – Perfluorpropylene
PP	Polypropylene

10 BONNET

The bonnet is connected with a form fit to the valve body providing, on the one hand, a potential compensation between the housing and bonnet and on the other a defined compression force for the body seal and bellows. The bonnet is provided with a blowout safety system. This means that the valve stem cannot be pulled or pressed upward out of the bonnet.

11 PLUG AND SEAT

The seat and plug are screwed, i.e. replacement is possible at any time when the Kvs value changes or for repair. The plug is screwed to the bellows and secured against loosening by a PTFE insert. For smaller Kvs values, a Hastelloy insert can be provided in the plug as well as in the seat (see Table 3).

The possible material combinations and available Kvs values and curves are shown in Table 3.

Table 3: Kvs / Cv values

									K _{vs} -value	C _v -value	Seat diameter (mm)	Rangeability	Plug material (standard)	Seat material (standard)	
Size DIN	15	20	25	25	40	50	80	100							
Size ANSI	0,5	0,75	1	1	1,5	2	3	4							
Stroke (mm)	10	10	10	20	20	20	40	40							
									0,011	0,013	3	50 : 1	Hast C276*	Hast C276*	
									0,017	0,020	3	50 : 1	Hast C276*	Hast C276*	
									0,025	0,029	3	50 : 1	Hast C276*	Hast C276*	
									0,04	0,047	3	50 : 1	Hast C276*	Hast C276*	
									0,063	0,074	3	50 : 1	Hast C276*	Hast C276*	
									0,1	0,12	4,5	50 : 1	Hast C276*	PTFE**	
									0,16	0,19	4,5	50 : 1	Hast C276*	PTFE**	
									0,25	0,29	4,5	50 : 1	Hast C276*	PTFE**	
									0,4	0,47	4,5	50 : 1	Hast C276*	PTFE**	
									0,63	0,74	4,5	50 : 1	Hast C276*	PTFE**	
									1,0	1,2	7	50 : 1	PTFE**	PTFE**	
									1,6	1,9	7	50 : 1	PTFE**	PTFE**	
									2,5	2,9	10	50 : 1	PTFE	PTFE	
									4,0	4,7	12	50 : 1	PTFE	PTFE	
									5,0	5,8	15	50 : 1	PTFE	PTFE	
									6,3	7,4	16	50 : 1	PTFE	PTFE	
									10	12	20	50 : 1	PTFE	PTFE	
									13	15	25	50 : 1	PTFE	PTFE	
									16	19	25	50 : 1	PTFE	PTFE	
									25	29	32	50 : 1	PTFE	PTFE	
									32	37	40	50 : 1	PTFE	PTFE	
									40	47	40	50 : 1	PTFE	PTFE	
									47	55	50	50 : 1	PTFE	PTFE	
									63	74	50	50 : 1	PTFE	PTFE	
									100	120	63	50 : 1	PTFE	PTFE	
									120	140	80	50 : 1	PTFE	PTFE	
									180	210	100	50 : 1	PTFE	PTFE	

* Hastelloy C276 inserts

** Optional Hastelloy C276 inserts

12 BELLOWS

The bellows seal is manufactured from modified PTFE. TF1620 for DN15, DN20 and DN25 and TFM1600 for sizes DN40, DN50, DN80 and DN100. The bellows is designed and tested on a standard basis for an operating pressure of 16 bars at 120 °C. The pressure/temperature limitations are limited only by the lining material, not the bellows: Observe the additional operating forces required by the bellows for sizing your actuator.

Table 4: Bellows seal

Size	Material	Stroke (mm)	Thrust (daN)	Part-No.	Effective area (cm ²)
DN 15	TF1620	10	110	132538500	6,4
DN 20	TF1620	10	110	132538500	6,4
DN 25	TF1620	10/20	52	132538600	8,6
DN 40	TFM1600	20	45	132538800	8,6
DN 50	TFM1600	20	45	132538800	8,6
DN 80	TFM1600	40	75	132538900	13,2
DN 100	TFM1600	40	75	132538900	13,2

13 STEM

The valve stem is equipped with a blowout protection feature. This ensures that the valve stem cannot be removed from the top of the valve. This is an important safety factor when the actuator is removed from the valve, because there would be otherwise no mechanical restriction.

Table 5: Valve stem materials

Valve stem	1.4571 (standard) 2.4819 (Hastelloy C276) (optional)
------------	---

14 PACKING

The 132000 valve series has a safety packing to back-up the bellows seal and to prevent leakage to the outside in the event of a bellows rupture.

15 TEST CONNECTION



WARNING: *If the optional test connection (1/4" NPT) is present, it must be sealed to prevent the medium from exiting in the event of a bellows rupture.*

16 QUICK CHECK

Before operating, check the valve as follows:

- 16.1 Open and close the valve and observe the movement of the actuator stem. The movement should be smooth and linear.
- 16.2 Check the minimum stroke by changing the control signal (for pneumatic position regulator 0.2 – 1.0 bar or corresponding “split range” values for IP position regulator 4-20 or 0-20 mA).
- 16.3 Check all air connections for leaks.
- 16.4 Check the packing nut (see Table 8).



CAUTION: *An excessively tightened gland nut can cause excessive packing wear and can hinder the free movement of the plug stem.*

- 16.5 Check fail-safe position. To do this, close supply pressure and observe whether the valve opens or closes as defined.
- 16.6 After use under varying temperatures, retighten all threaded connections and check for leaks.

17 MAINTENANCE

Check for proper function at regular intervals as follows. These checks can be accomplished in the installed state and, in many cases, without shutting down production. If internal defects are suspected, see section “Disassembly and assembly of valve”.

- 17.1 Check gaskets for leakage and retighten bolts if required (see Fig. 1).
- 17.2 Check bellows seal, test connection and body drain screw – if present – for leakage to the outside.
- 17.3 Check valve for damage resulting from corrosive process residues or corrosive vapors.
- 17.4 Clean valves and repaint as required.
- 17.5 Check packing nut (see Table 8).



CAUTION: *An excessively tightened gland nut can cause excessive packing wear and can hinder the free movement of the plug stem.*

- 17.6 If possible, open and close valve and check for maximum stroke and ensure that the plug stem moves without jerking. Irregular motion of the plug stem can indicate an internal defect



WARNING: *..Keep hands, hair, clothing, etc. away from all moving parts. Failure to observe can lead to severe injuries.*

- 17.7 Ensure that all accessory parts are seated tightly.
- 17.9 Connect air supply and check safety position.
- 17.10 Check air filter, if present, and replace element as necessary.

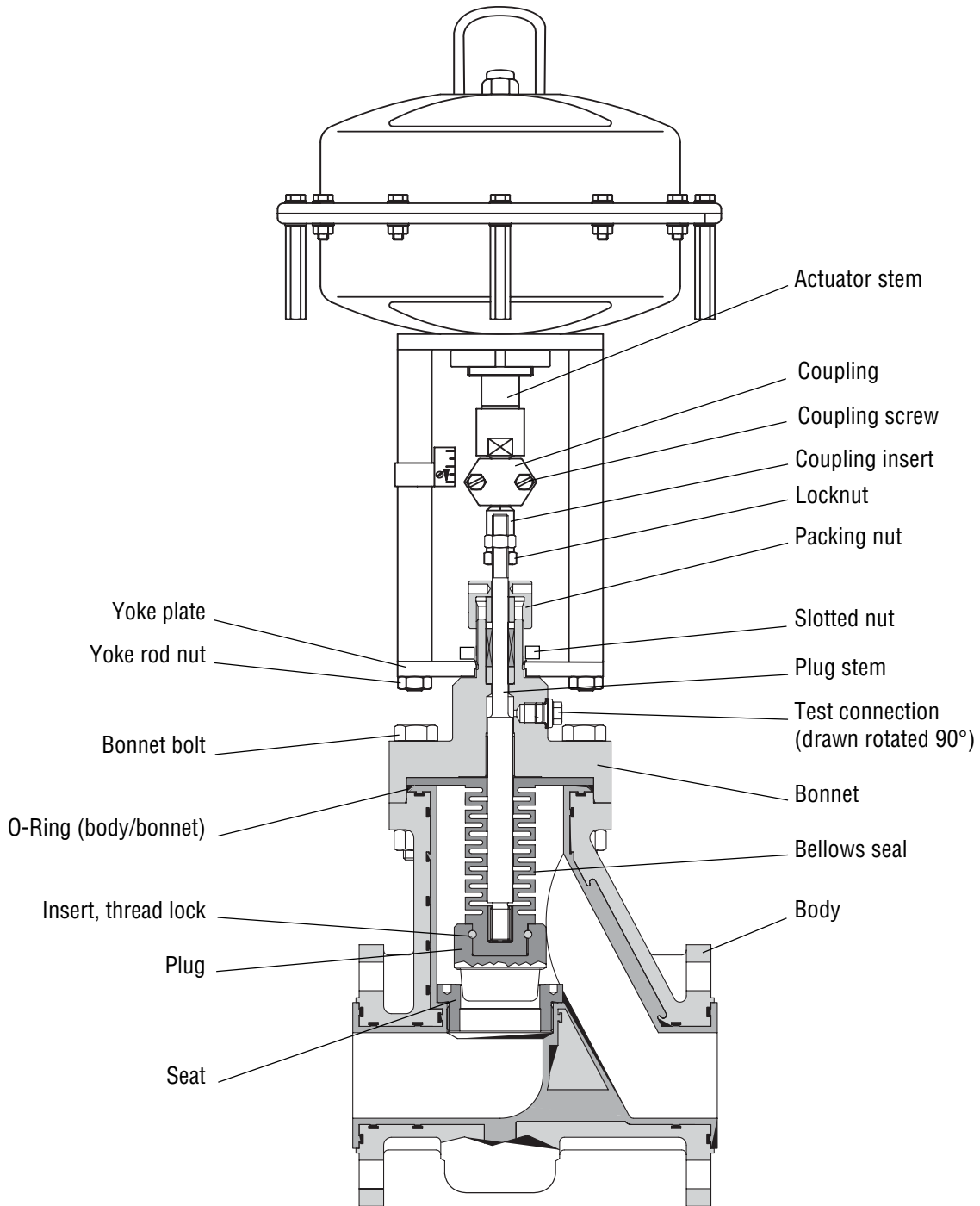

Fig. 1: Typical valve series 132000 with series 2 actuator

18 REMOVING ACTUATOR FROM VALVE

(See Fig. 1)

18.1 Shut off air supply.



DANGER: ..Ensure that actuator is not under pressure and drain process medium before performing maintenance work. Failure to observe can lead to serious injuries.

18.2 Remove piping if required.

18.3 Remove 2 coupling bolts and remove coupling.

18.4 Loosen yoke stem nuts and remove. Carefully remove actuator from valve.

18.5 After loosening counternut, unscrew coupling insert (caution: hold plug with wrench on coupling insert to prevent turning).

19 ATTACHING ACTUATOR TO VALVE

(see Fig. 1)

The actuator stem must be fully extended:

Actuators with air-to-open action must be fully vented. Actuators with air-to-close action apply supply pressure.

Manually depress the plug stem to ensure the plug is fully seated.

The valve plug must make contact in the valve seat, i.e. press valve stem in all the way by hand.

19.1 Screw coupling insert locknut and coupling insert as far as possible onto plug stem.

19.2 Place the actuator assembly on the valve engaging the yoke rod threads in the lower yoke plate and ensuring the actuator faces in the correct direction.

19.3 Unscrew the coupling insert until the yoke rods are raised from the lower yoke plate by around 2 mm.



NOTE: Ensure that the plug assembly is not rotated with the plug seated. This may cause irreparable damage to the seating faces.

19.4 Refit the coupling, ensuring that the arrows, embossed on the coupling halves, point upward towards the actuator, and secure with 2 retaining screws.

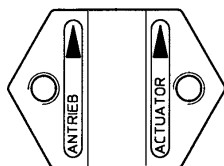

9.5 Apply supply pressure resp. vent actuator to half stroke and refit and tighten yoke rod retaining nuts.

19.6 Reconnect all tubing.

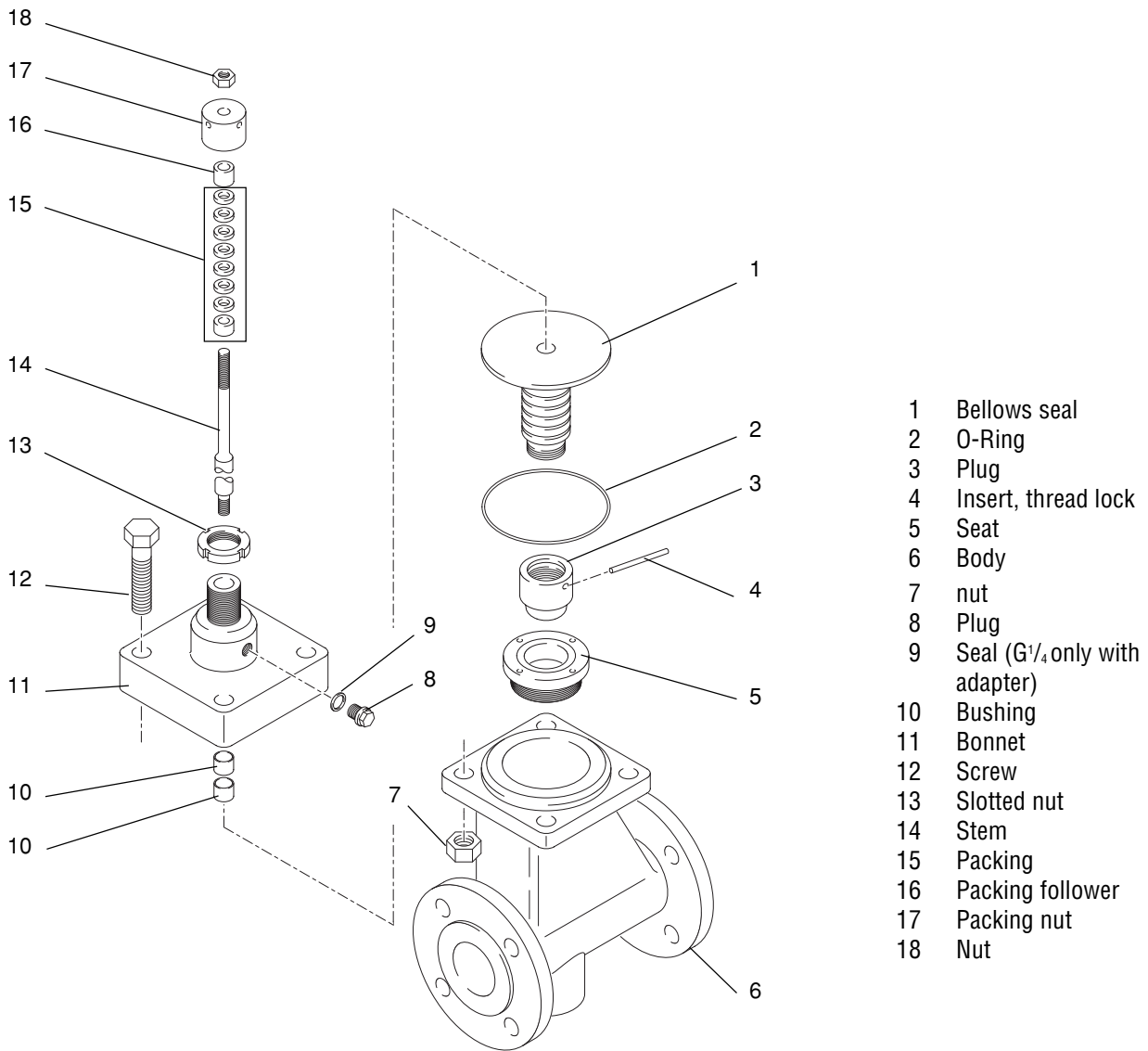

Fig. 2: Individual parts for series 132 000
(also see spare parts lists)

Table 6: Tightening torque for seat (Nm)

DN 15	DN 20	DN 25	DN 40	DN 50	DN 80	DN 100
3	3	6	16	16	28	30

Table 7: Tightening torque for bonnet fasteners (Nm)

DN 15	DN 20	DN 25	DN 40	DN 50	DN 80	DN 100
60	60	60	145	145	145	280

DISASSEMBLE AND ASSEMBLE VALVE

20 DISASSEMBLE VALVE

(see Fig. 2)



DANGER: *Since toxic or hazardous substances could be present, release all pressure in the system and drain all process substances. If necessary, decontaminate valve. Keep hands, hair and clothing away from moving parts. Wear face and eye protection. Failure to observe can lead to severe injuries.*

20.1 Carefully loosen test connection and check whether medium has collected in bellows cap (bellows defective).

20.2 Remove bolts/nuts from bonnet and remove bonnet.



Note: *Due to packing friction the bellows/plug is usually pulled out when the bonnet is removed. In such cases, hold the bellows/plug so that it cannot fall and be damaged.*

20.3 If the bellows remains in the housing, it can be pried out carefully with two screwdrivers.

20.4 Without stretching the bellows, remove the plug/bellows assembly from the bonnet. Press guides, packing and spacer out of packing chamber from below with a punch (the punch diameter should be slightly larger than the plug stem).

20.5 If required, pull out thread lock insert with a pair of pliers and unscrew plug from bellows.



WARNING: *..When the plug is loosened, medium residues can be released which have leaked through the thread.*

20.7 Unscrew seat ring with seat ring wrench.

20.8 Check sealing edges on seat ring and plug for damage. The sealing surfaces must be clean and free of damage.



WARNING: *..To avoid damage to the seat, plug or plug stem, observe the preceding instructions exactly.*

21 ASSEMBLE VALVE

(see Fig. 2)

21.1 Replace all worn or damaged parts. Use only genuine FLOWSERVE parts. Parts to be reused must be clean. Always replace parts subject to wear such as gaskets, packings and O-rings.

21.2 Insert seat ring and tighten (see Table 6 for torque).

21.3 Screw plug onto bellows hand-tight and insert a new thread lock insert. Cut off thread lock insert so that approx. 3 mm extends from the hole.

21.4 Carefully insert plug stem with bellows into bonnet.

21.5 Position new O-ring on inclined surface on top of housing.

21.6 Position bonnet slowly and absolutely upright on body, to avoid damage to seat/plug.

21.7 Insert bonnet mounting bolts and tighten hand-tight in crisscross pattern.

21.10 Tighten all bolts to specified torques in crisscross pattern with torque wrench (see Table 7).

21.11 Replace packing by inserting packing rings one at a time tapping each one down with a suitable bushing.



NOTE: *ensure that the gaps in the packing rings are distributed evenly around the circumference in the packing box (gaps **not** in line).*

Different packings and fitting sequencess are shown in the spare parts list.

21.12 Insert packing follower and tighten packing nut (see Table 8).

21.13 During the subsequent pressure test, ensure that the pressure does not exceed the maximum permissible pressure for the bellows (PN16). After checking the test connection for leakage – if present – plug with a plug or appropriate pressure gauge.

Table 8: Tightening totque for packing nut (Nm)

Thread	PTFE Packing	Grafoil Packing
M20 x 1,5	1	3
M30 x 1,5	6	15
M38 x 1,5	15	35
M45 x 1,5	17	40

22 Troubleshooting chart

Fault	Possible Cause	Remedy
Stem motion impeded	<ol style="list-style-type: none"> 1. Packing excessively tightened 2. Operating temperature too high for selected trim 3. Supply pressure inadequate 4. Positioner defective 	<ol style="list-style-type: none"> 1. Tighten gland nut (see table 1) 2. Note operating data and contact dealer 3. Check system for leaks in the supply pressure or signal lines. Re-tighten the connections, if necessary replace leaky lines 4. See operating instructions for positioner
Excessive leakage	<ol style="list-style-type: none"> 1. Bonnet loose 2. Worn or damaged seat ring/plug 3. Gaskets damaged 4. Inadequate actuator thrust 5. Plug incorrectly adjusted 6. Incorrect direction of flow 7. Handwheel incorrectly adjusted (acts like end stop) 	<ol style="list-style-type: none"> 1. See step 21.7 for correct tightening of bonnet. 2. Re-machine or replace seat ring/plug. 3. Replace gaskets 4. Check air feed. If air feed is OK, contact dealer. 5. Correctly adjust plug according to step 18.3 6. Check specification. Contact dealer 7. Adjust handwheel
Inadequate flow	<ol style="list-style-type: none"> 1. Plug incorrectly adjusted (short stroke) 2. Positioner defective 3. Operating requirements too high 	<ol style="list-style-type: none"> 1. Correctly adjust plug according to step 18.3 2. See operating instructions for positioner 3. Check operating data. Contact dealer
Plug slams	<ol style="list-style-type: none"> 1. Plug adjustment incorrect 2. Inadequate supply pressure 3. Trim too large for flow rate 	<ol style="list-style-type: none"> 1. Correctly adjust plug according to step 18.3 2. Check supply pressure, seal leaks, remove blockage 3. Replace trim

Regional Headquarters
Flowserve EMA

Burrell Road, Hayward Heath
West Sussex, RH16 1TL
England
Telephone: +44 (0) 1444 314400
Facsimile: +44 (0) 144 3144401

Flowserve America

1350 N. Mt. Springs Prkwy.
Springville, UT 84663
USA
Telephone: +1 801 489 8611
Facsimile: +1 801 489 3719

Flowserve Asia

12 Tuas Avenue 20
638824
Republic of Singapore
Telephone: +65 862 3332
Facsimile: +65 862 4940

Main Sales Offices EMA (Europe, Middle East, Africa)
Flowserve France

7 Avenue de la Libération
63300 Thiers Cedex
France
Telephone: +33 (0) 4 73 80 42 66
Facsimile: +33 (0) 4 73 80 14 24

Flowserve UK

Station Road
Persnore, Worcestershire
England WR102BZ
Telephone: +44 (0) 1386 55 45 51
Facsimile: +44 (0) 1386 55 49 68

Flowserve Switzerland

Allee du Quartz 1
CH-2300 La-Chaux-de Fonds
Switzerland
Telephone: +41 (0) 32 925 9700
Facsimile: +41 (0) 32 926 5422

Flowserve Germany

Manderscheidstr. 19
45141 Essen
Germany
Telephone: +49 (0) 201 8919 5
Facsimile: +49 (0) 201 8919 662

Flowserve South Africa

Units 1 and 2
26, Imvuba Road, Sebenza Ext 6
Edenvale, Gauteng
Edenglen 1613
South Africa
Telephone: +27 11 609 2094
Facsimile: +27 11 609 3735

Flowserve Middle-East

C/O Saleh & Abdulaziz Abahsain
P.O. Box 209
Al Khobar 31952
Saudi Arabia
Telephone: 9663 857 3442
Facsimile: 9663 859 5284

Flowserve Austria

Kasernengasse 6
9500 Villach
Austria
Telephone: +43 (0) 424241 181-0
Facsimile: +43 (0) 424241 181 50/51

Flowserve Benelux

Van Leeuwenhoekweg 6
3225 LX Hellevoetsluis
The Netherlands
Telephone: +31 (0) 181 330044
Facsimile: +31 (0) 181 330040

Flowserve Italy

Via Prealpi, 30
Cormano (Milano)
Italy
Telephone: +39 (0) 2663251
Facsimile: +39 (0) 26151863

Flowserve Spain

Luis Cabrera, 86-88
E-28002 Madrid
Spain
Telephone: +34 9 15 152 032
Facsimile: +34 9 14 136 747

Flowserve Portugal

Av. Dr. Antunes Guimaraes, 1159
Porto 4100-082
Portugal
Telephone: +351 22 619 8770
Facsimile: +351 22 619 7575

Flowserve Scandinavia

Gelbgjutaregatan
58933 Linköping, Östergötland
Sweden
Telephone: +46 13 316100
Facsimile: +46 13 136054

Flowserve Eastern Europe

12, av. du Québec
91965, Courtaboeuf Cedex
France
Telephone: +33 (0) 1 60 923 251
Facsimile: +33 (0) 1 60 923 299

All data subject to change without notice