



REMOTE CONTROL

RCI 400 SERIES Installation & Maintenance Instructions (Including Parts List)

P.O. Box 275 • North Kingstown, RI 02852 • Phone: 401-294-1400 • Fax: 401-294-3388
E-mail: sales@rciactuators.com • Website: www.rciactuators.com

INSTALLATION & OPERATING INSTRUCTIONS

LUBRICATION

- All moving parts are factory lubricated for cycle life with no further lubrication required.
- When applied to high cycle or severe environmental conditions relubrication may be required.

SUPPLY

- Filtered dry or lubricated air, clean chemical-free water or light hydraulic oil may be used.
- Use of other non-corrosive gases should be verified by factory prior to use.

EMERGENCY OPERATION

- Actuators must be fully de-pressurized prior to manual operation, using suitable vent valves.
- Double acting actuators may be manually operated using suitable hand levers or gear boxes, as required.
- Spring return actuators should be provided with suitable de-clutchable gear boxes to prevent injury.

INSTALLATION

- Actuators may be mounted in any orientation; however, care should be taken in those cases where certain instrumentation may be sensitive to specific orientation.
- When installing actuator on valve, insure that actuator drive bore and valve shaft are in alignment. Mis-alignment may cause excessive friction, binding and/or premature seal failure. Actuators should be stroked to verify proper alignment.

ADJUSTMENT

- Actuators have a 90 degree stroke, which may be adjusted ± 3 degrees by adjusting screws in the end cap.

MAINTENANCE INSTRUCTIONS

WARNING: Prior to disassembly of actuator, insure that the air supply and all electrical connections have been disconnected.

TO DIS-ASSEMBLE ACTUATOR

- Remove end bolts (18) from end cap (3) using cross corners method to equalize bolt loading.
- Remove end caps (3).
- Rotate pinion (4) counter-clockwise to remove pistons (2) from body (1). (Clockwise if set up for F.O.) When viewed from accessory side. (Top)
- After piston removal, remove circlip (10) from pinion (4).
- Removal of circlip (10) allows the pinion (4) to be removed from the body by lightly pressing from accessory side.

PARTS REPLACEMENT

- Replace as necessary, or replace all "soft goods" as contained in repair kit. This consists of piston guide (5), pinion guide ring (6), "O" ring (7), pinion guide ring (8), "O" ring (9), plug (12), "O" ring (19), piston guide ring (20) and "O" ring (21).

RE-ASSEMBLE IN REVERSE ORDER

- Install pinion (4), thrust washer (11), and circlip (10).
- Install pistons (2) by pushing into cylinder simultaneously and rotating pinion (4).
- Install end caps (3) (with springs if SR) and bolt in place using cross corners bolting sequence.
- Reinstall solenoids, switches, etc.
- Actuator is ready for re-installation on valve.

SPRING ADDITION, DELETION, REPLACEMENT

- Disassemble actuator end caps as described above.
- Spring cartridges (13) may be added or deleted as required to obtain the appropriate spring end torque.
- Springs are to be installed in specific locations dependent on number, shown as solid circles in figure A.
- Reassemble actuator end caps.

Figure A

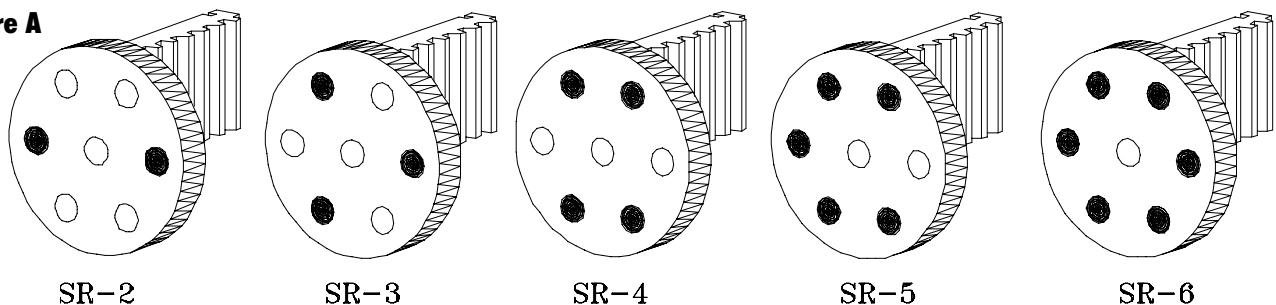

PARTS LIST FOR RCI 400

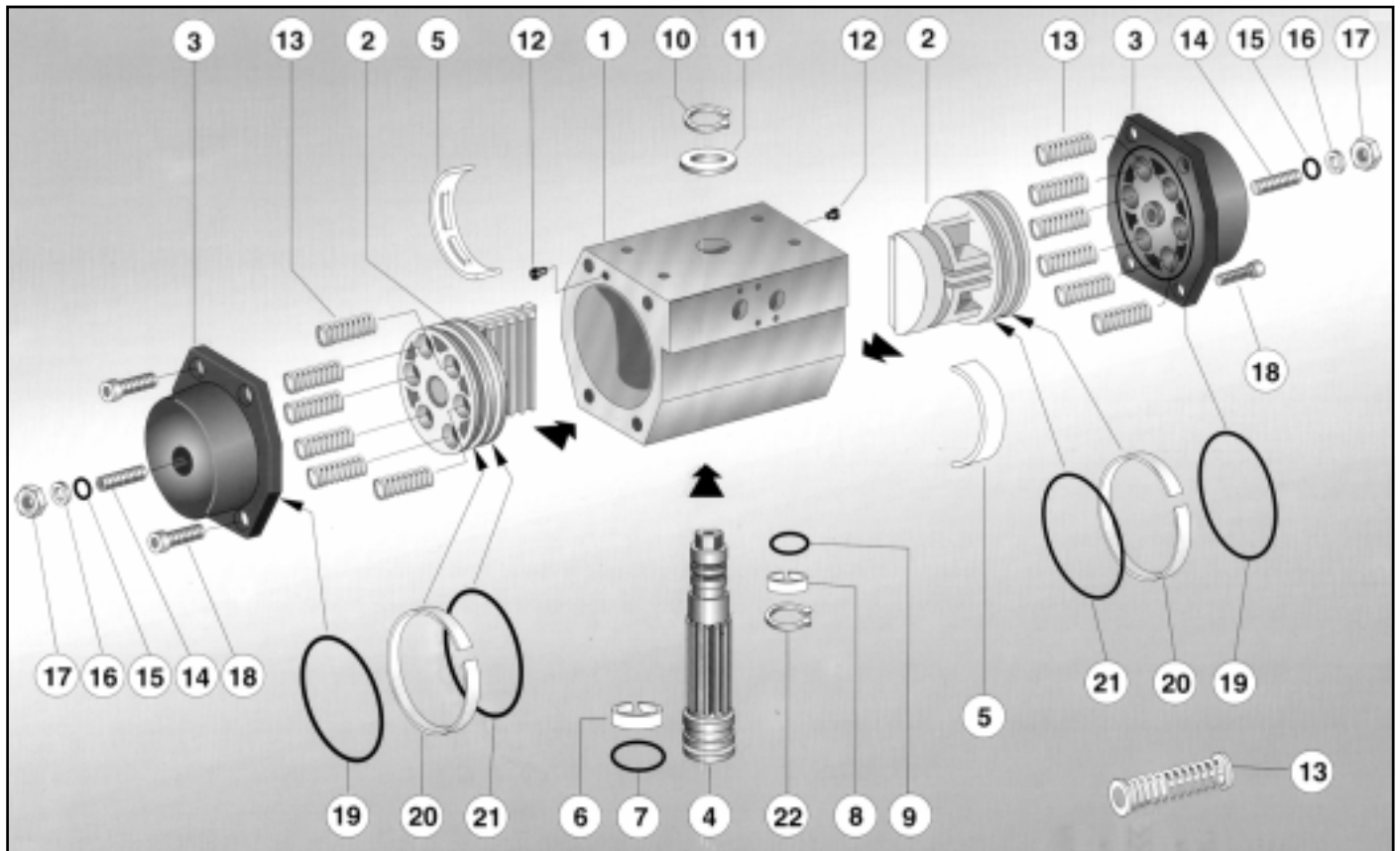

Item	Parts List	Qty
1	Actuator Body	1
2	Piston	2
3	End Cap	2
4	Pinion	1
*5	Piston Guide	2
*6	Pinion Guide Ring	1
*7	"O" Ring	1
*8	Pinion Guide Ring	1
*9	"O" Ring	1
10	Circlip	1
11	Thrust Washer	1
*12	Plug	2
13	Pre-Loaded Springs	4-12
14	Screw, External Stroke Adjustment	2
15	"O" Ring	2
16	Plain Washer	2
17	Stop Nut	2
18	End Cap Bolts	8
*19	"O" Ring	2
*20	Piston Guide Ring	2
*21	"O" Ring	2
22	Circlip Anti Blow Out	1

* Recommended spare parts. (Repair Kit)