

Valtek Valdisk Control Valves

GENERAL INFORMATION

The following instructions are designed to assist in unpacking, installing and performing maintenance as required on Valdisk rotary valves. Product users and maintenance personnel should thoroughly review this bulletin prior to installing, operating, or performing any maintenance on the valve.

Separate maintenance instructions cover additional features (such as actuators, positioners, special accessories, fail-safe systems, etc.) Refer to the appropriate Flowserve Installation, Operation, Maintenance Instructions when information on installing, maintaining, troubleshooting, calibrating, and operating Valtek® actuators or positioners is required.

To avoid possible injury to personnel or damage to valve parts, WARNING and CAUTION notes must be strictly adhered to. Modifying this product, substituting non-factory parts, or using maintenance procedures other than outlined could drastically affect performance, be hazardous to personnel and equipment, and may void existing warranties.

WARNING: Standard industry safety practices must be adhered to when working on this, or any other, process control product. Specifically, personal protective and lifting devices must be used as warranted.

Note: *Selecting the proper fastener material is the responsibility of the customer. Typically, the supplier does not know what the valve service conditions or environment may be. Valtek's standard body bolting material is B7/2H. B8 (stainless steel) is optional for applications above 800° F and with stainless steel or alloy body valves. The customer therefore must consider the material's resistance to stress corrosion cracking in addition to general corrosion. As with any mechanical equipment, **periodic inspection and maintenance is required.** For more information about fastener materials, contact your local Valtek representative or factory.*

Unpacking

1. While unpacking the valve, check the packing list against the materials received. Lists describing the valve and accessories are included in each shipping container.
2. When lifting the valve from the shipping container, position lifting straps to avoid damage to tubing and mounted accessories. Valves up through 14-inch may be lifted by the actuator lifting ring. On larger valves, lift the valve using lifting straps or hook through the yoke legs and outer end of the body.
3. In the event of shipping damage, contact your shipper immediately.
4. Should any problem arise, contact your Valtek representative.

Table 1: Flange Bolting Torques

Valve Size (Inches)	Rating	Torque Carbon Steel (ft-lbs)	Torque Stainless Steel (ft-lbs)
2	150	118	74
	300	118	74
	600	118	74
3	150	118	74
	300	209	131
	600	209	131
4	150	118	74
	300	209	131
	600	337	211
6	150	209	131
	300	209	131
	600	505	316
8	150	209	131
	300	337	211
	600	728	455
10	150	337	211
	300	505	316
12	150	337	211
	300	728	455
14	150	505	316
16	150	505	316
18	150	728	455
20	150	728	455
24	150	1009	631
30	150	1009	631

*Note: All values are + or - 10%

Installation

1. Before installing the valve, clean the line of dirt, scale, welding chips, and other foreign material. Clean the gasket surfaces thoroughly to insure leak-proof joints.
2. Check flow direction to be sure valve is installed correctly. Fail-closed valves should be installed with the **shaft upstream only on gas service**. It is preferred that liquid service valves must be installed with the shaft downstream regardless of air failure action. However, under certain flow conditions the valve can flow shaft upstream. Consult factory if the valve must be mounted with the shaft upstream in liquid service. Fail-open valves should be installed with the shaft downstream.

WARNING: When installing the valve in-line between flanges, make certain the flange face gasket covers both seat retainer and body and surface. Failure to do so will cause excessive leakage downstream. Refer to iSeat Insert/Snap-ring Configurationi in Figure 1.

3. Fully close the valve before and during the installation process.

WARNING: Keep hands, hair, clothing, etc. away from the rotating disc and the seat when operating the valve. Failure to do so could cause serious injury.

CAUTION: Because of Valdisk's self-centering seat, there is no reason to open the valve at any time during installation. Therefore, the valve should remain closed until the valve is fully installed.

4. Connect air supply and instrument signal. Throttling valves are usually equipped with valve positioners. Two connections are marked for the air supply and for the instrument signal. Both cylinder and positioner are suitable for 150 psi air supply. An air regulator is not required unless the supply pressure exceeds 150 psi. An air filter is recommended unless the supply air is unusually clean and dry. All connections must be free of leaks.

CAUTION: On valves equipped with air filters, the air filter bowl must point down; otherwise, the air filter will not perform properly.

NOTE:

5. Make sure proper clearance exists internally in the mating piping to permit proper disc rotation.
6. Apply recommended torque values to line flange bolting for proper sealing (see Table 1).

Quick-check

Prior to start-up, check the control valve by following these steps:

1. Check for full stroke by making the appropriate in-instrument signal change. Observe disc position indicator plate mounted on the transfer case. The disc should change position in a smooth, rotary fashion.
2. Check all air connections for leaks. Tighten or replace any leaky lines.
3. Evenly tighten the packing nuts to slightly over finger-tight.

CAUTION: Do not overtighten packing. This can cause excessive packing wear and high shaft friction, which may impede shaft rotation.

After the valve has been in operation for a short time, check the packing nuts to make sure they are just over finger-tight (readjust if necessary). If packing box leaking occurs, tighten the packing nuts only enough to stop leakage.

4. To observe the valve failure mode in case of air failure, position the valve to mid-stroke and shut off the air supply or disconnect the instrument signal. By observing the indicator plate, the disc should either fail open or closed. If incorrect, refer to the iReversing the Actuatori section in the appropriate Actuator Maintenance Instructions.

PREVENTIVE MAINTENANCE

At least once every six months, check for proper operation by following the preventive maintenance steps outlined below. These steps can be performed while the valve is in line and, in some cases, without interrupting service. If an internal problem is suspected, refer to the Disassembly and Reassembly section.

1. Look for signs of gasket leakage through body and line flanges. Tighten flange bolting if necessary.
2. Note if any corrosive fumes or process drippings are damaging the valve.
3. Clean valve and paint any areas of severe oxidation.
4. Check packing box bolting for proper tightness. Packing nuts should be slightly over finger-tight; however, tighten as necessary to prevent stem leakage.

CAUTION: Do not overtighten packing.

5. If valve is supplied with a lubricator, check lubricant supply and add lubricant if necessary.
6. If possible, stroke valve and check for smooth, full-stroke operation by observing the disc position indicator plate mounted on the transfer case. Unsteady movement of the disc could indicate an internal valve problem (jerky motion is normal whenever Grafoil packing is used).
7. Check positioner calibration by observing the gauges and the disc position indicator plate. Make sure the positioner is calibrated to the correct range. Push the positioner cleanout plunger (Model 80R positioner only) several times to clear any possible restrictions.
8. Remove transfer case cover plate and make sure the positioner linkage and internal actuator parts are securely fastened. Also, check for air leaks through actuator stem seal, using a soap solution.

CAUTION: Never apply air to the actuator without the cover plate installed; otherwise, the unsupported shaft may sustain damage.

9. Be sure that all accessories, brackets and bolting are securely fastened.
10. If possible, remove air supply and observe stroke plate for correct fail-safe action.
11. Spray soap solution around the cylinder retaining ring and the adjusting screw to check for air leaks through the O-rings.
12. Clean any dirt or other foreign material from the exposed portion of the shaft.
13. If an air filter is supplied, check and replace cartridge if necessary.

DISASSEMBLY AND REASSEMBLY

Removing Valve From Line

If an internal problem is suspected with the valve and disassembly is required, remove the valve from the line by proceeding as follows:

WARNING: Depressurize line to atmospheric pressure, drain all process fluids and decontaminate the valve (if caustic or hazardous materials are present). Failure to do so can cause serious injury.

1. Make sure valve is fully closed.

Note: On valves with fail-open action, air pressure must be supplied under the actuator piston to close the valve. If the valve is supplied with a handwheel, it can be used to close the valve.

2. Attach a hoist or some means to support the valve.
3. Remove the line bolting. Do not attempt to pry line flanges apart by pushing or pulling on valve actuator.
4. Slide the valve carefully from the line. To avoid damage to gasket surfaces, do not twist the valve.

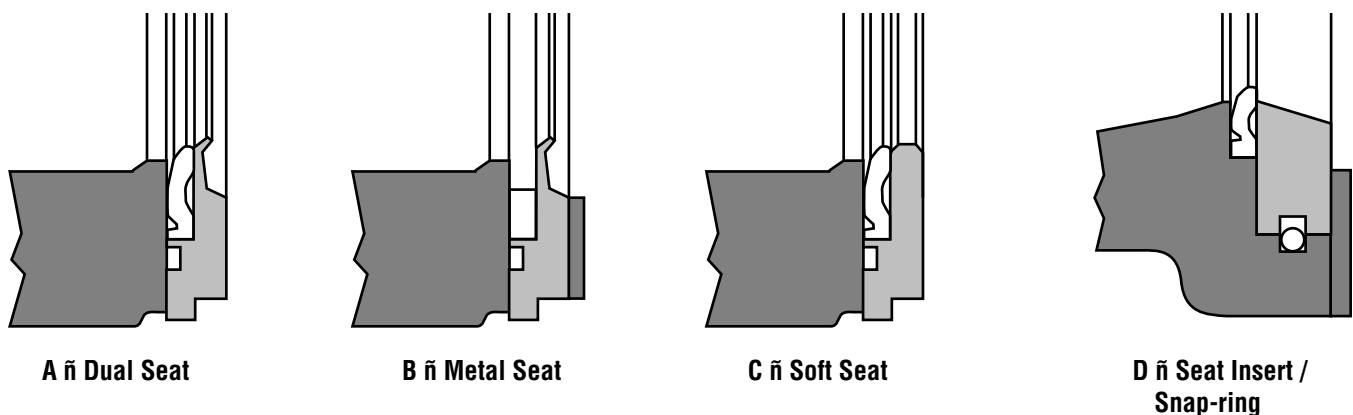

Figure 1: Seat Retainer Configurations

NOTE: Item numbers correspond directly to the bill of material. Refer to the bill of material for specific part numbers.

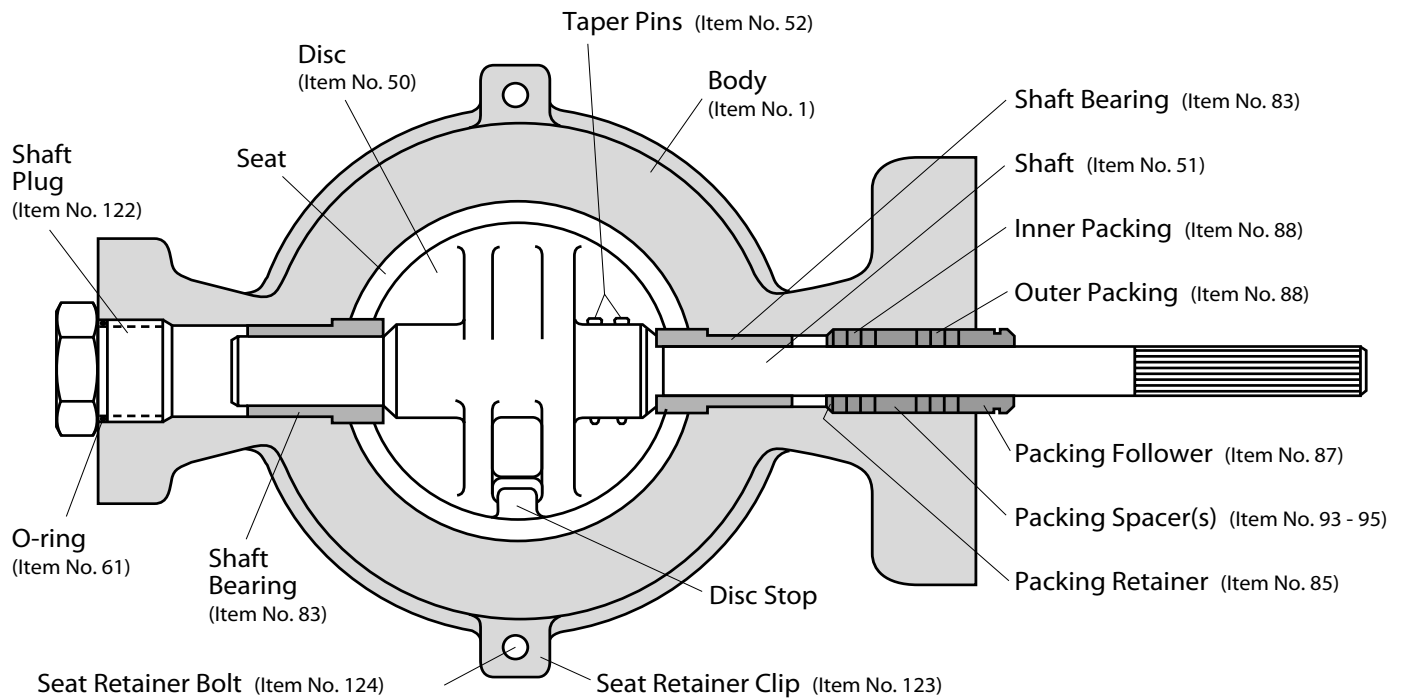

Figure 2: Body Assembly

NOTE: Item numbers correspond directly to the valve's bill of material. Refer to it for specific part numbers.

5. After the valve is completely removed from the line, slowly relieve air pressure from the actuator.

Removing Actuator From Body

In most cases, both the body assembly and the actuator are easier to disassemble with the actuator removed from the body. To do so, proceed as follows:

1. Support actuator assembly by the lifting ring before disconnecting it from the body assembly.
2. Remove the transfer case cover bolts. Carefully pry or slide the cover plate from the end of the shaft.
3. On Valtek actuators with a clamping lever arm design, loosen the linkage bolt.
4. Loosen the actuator adjusting screw to release spring pressure.
5. Remove the bolts connecting yoke to the actuator subassembly.
6. Slide entire actuator assembly off the shaft. For Valtek actuators with a clamping lever-arm design, it may be necessary to wedge the halves of splined lever arm apart to loosen it from the shaft splines.

Disassembling the Body

To disassemble the body, refer to Figures 1, 2 and 5 and proceed as follows:

1. On Valdisk valves supplied with seat retainer screws, remove the seat retainer screws and retainer clips. Lift the seat retainer out of the valve body. (Refer to Figures 1A, B, C).
2. On valves supplied with retainer snap-ring configuration, carefully insert a screwdriver in the key slot provided in the retainer; pry the retainer and snap ring out of the valve body. (Refer to Figure 1D).
3. Remove the gland flange by removing both packing nuts. It is not necessary to remove the studs.
4. Drive the taper pins out of the disc by tapping on the small end of the pins using a punch and hammer.
5. Remove the end plug (optional bolted flange and seal if applicable).
6. Remove shaft by inserting a press or a nylon rod (or similar material) into body's blind end, and using a hammer, carefully tap the shaft through the body.

CAUTION: Take special care not to damage the splined end of the shaft during disassembly.

To prevent scratching the sealing surface of the disc while removing the shaft, place supports underneath the disc. This also prevents the shaft from binding in the body as the shaft comes off the bearing surfaces.

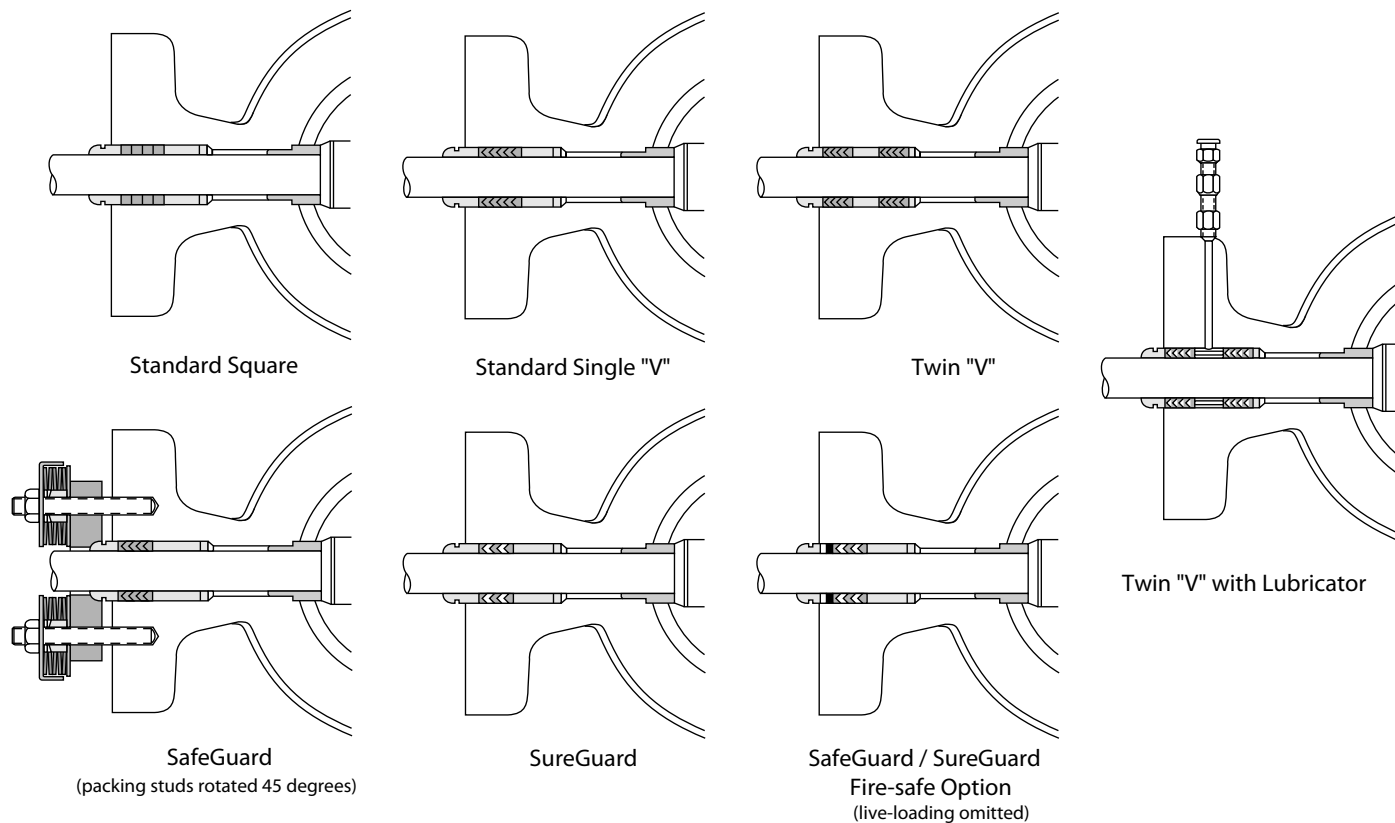

Figure 3: Typical Packing Configurations

7. Push the packing and bearings out of the body using a dowel of appropriate diameter. Push the packing from the center of the valve.

Reassembling the Body

To reassemble the body sub-assembly, refer to Figures 1, 2, 3, and 5 and proceed as follows:

1. Clean all parts.
2. Check the disc seating surface to make sure it is smooth and free of scoring and scratches.

CAUTION: Damaged or dirty seat surfaces can cause excessive seat wear and high torque requirements. Damaged discs should be replaced.

3. Inspect shaft for scratches or galled surfaces. For maximum performance, Valdиск shafts are machined to a very smooth finish. If damage exists, replace the shaft or contact factory representative.

NOTE: *Disc and shaft are interchangeable in recent designs. Replacing the disc does not require replacing the shaft. Earlier designs require that the disc and shaft be machined together. Contact the factory for matched disc and shaft.*

4. Insert new sliding stem shaft bearings into the body. (A press may be required with some designs.)

NOTE: *Earlier Valdиск designs require the disc to be aligned with the body in such a way that it can rotate properly. Align the shaft bearings on either side of the disc and*

insert the shaft through the body, bearings and disc.

5. Position the disc in the body, making sure it will rotate in the proper direction with respect to the body's internal disc stop. Slide the shaft through the body, bearings and disc.

CAUTION: Exercise care while sliding the shaft into the sliding stem shaft bearings to avoid damage to both the shaft and bearings.

6. Insert new taper pins and drive them firmly into place in the side opposite the stop.
7. Slide the packing retainer, lower packing, packing spacer, upper packing, and packing follower over splined end of the shaft and into the body. Typical packing configurations are shown in Figure 3.

NOTE:

CAUTION: Since the sealing on V-ring packing takes place at the feather edge, it is important to avoid damage to that edge.

8. Reinstall the end plug (or replace the end seal and reinstall the bolted flange).
9. Reinstall the gland flange and packing nuts. Tighten packing evenly to slightly over finger-tight.

CAUTION: Do not overtighten packing. This can cause excessive packing wear and high shaft friction, which may impede shaft rotation.

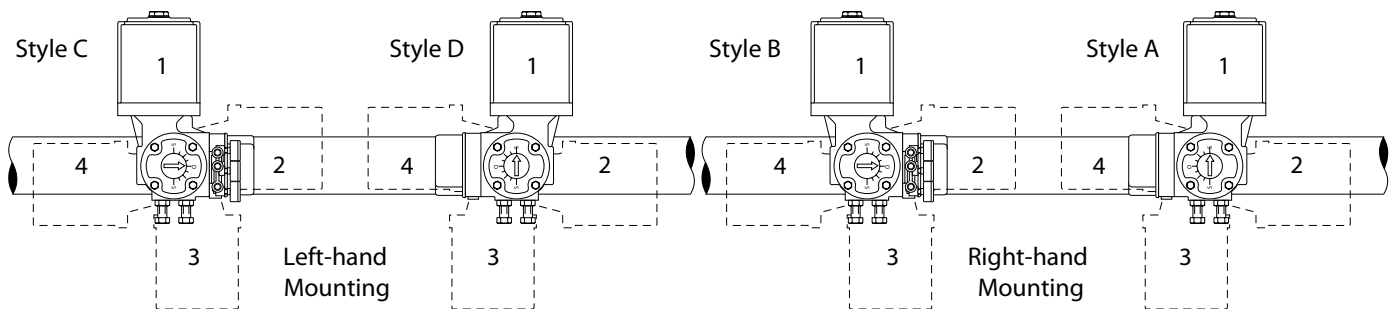
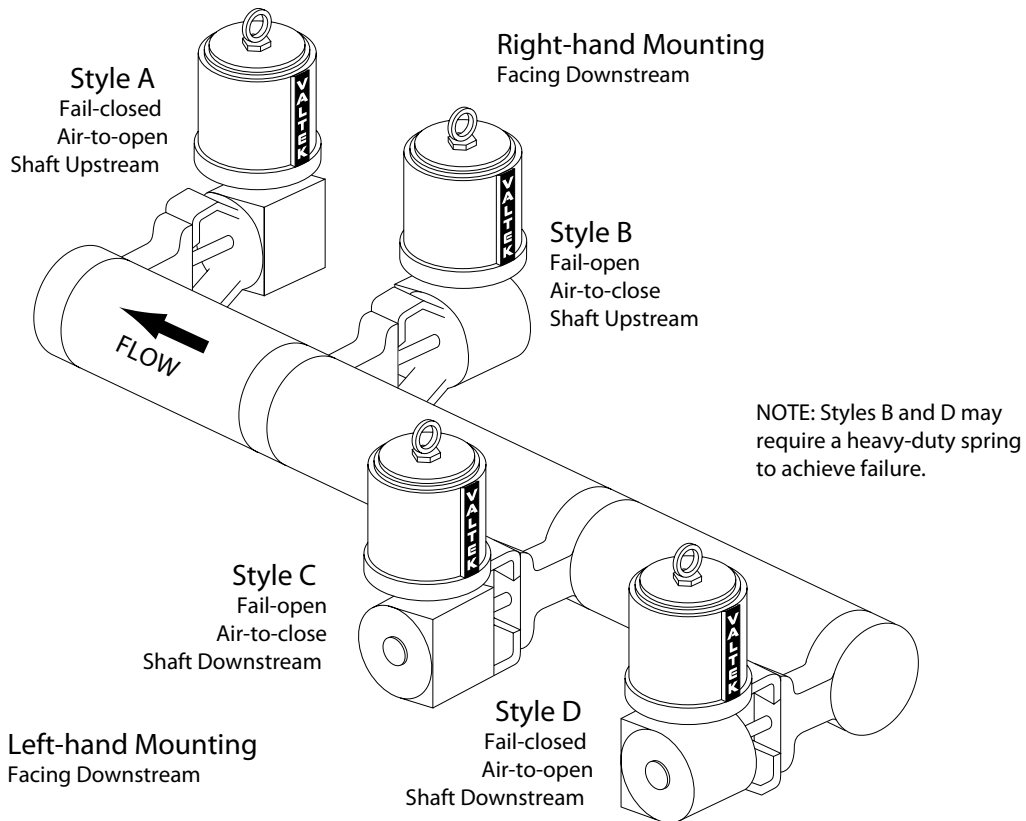

NOTE: Orientation 1 is standard. Orientation positions 2 and 4 are not available in some actuator sizes. Contact factory.

Figure 4: Transfer Case Mounting

10. All seat configurations with screw/clip retainers require a gasket (item #55) installed in the appropriate groove. This is accomplished by pressing the gasket into the appropriate groove.
11. If the seat retainer is the screw/clip type and has a soft or dual seat, press the soft seat into the soft seat retainer or metal seat. (There should be an interference between the soft seat and the retainer.) With the valve in the closed position, secure the retainer or metal seat in place by tightening the retainer clips and screws. This allows the seat to align with the disc, permitting tight shutoff.
12. If the seat retainer is the screw/clip type with a metal seat design, a gasket will need to be installed in the metal seat

prior to clipping the seat in place with the seat clips and screws.

NOTE: *Valdisk valves of earlier design may require that the disc be open while installing the soft seat into the body. (Refer to Figure 1D.)*

13. If an early design Valdisk seat retainer has an indexing groove to accept a soft seat, press the corresponding seat into the retainer groove. Install the seat retainer subassembly into the body.
14. On valves supplied with the retainer snap-ring configuration, install the snap-ring into the groove around the retainer (or metal seat). Start the retainer into the body with the open ends of the snap-ring in the body groove.

Gently press the snap-ring into the retainer until both the retainer and snap-ring slip into the body. (Refer to Figure 1D.)

15. On early design Valdisk valves supplied with seat retainer screws, install the insert and retainer into the body with the disc open. Loosely install the retainer screws, then close the disc. Tighten the screws after the closed disc has centered the seat. This allows the seat to align with the disc, permitting tight shutoff.

Remounting Actuator to Valve

Before mounting a Valtek actuator on the valve body, verify that the disc rotation matches the actuator rotation and complies with the air failure requirements. Procedure for mounting the actuator is as follows:

1. Slide the entire actuator assembly onto the shaft. If necessary on Valtek actuator designs with clamping lever arm design, wedge the splined lever arm apart to loosen it on the shaft splines. For full rotation of the disc, marks pro-

vided on the end of the shaft and on the lever arm should be aligned.

2. Bolt the actuator yoke to the valve body. Be certain the stroke indicator plate is positioned properly to accurately indicate the valve's rotation.
3. Position the actuator lever arm on the shaft so the actuator stem is centered in the transfer case. Firmly tighten the linkage bolt, on clamping lever arm actuators.
CAUTION: On clamping lever-arm actuators, do not apply air to the actuator without the cover plate installed; otherwise, the unsupported shaft may sustain damage.
4. Adjust the actuator stroke stop bolts until the disc is parallel to the seat surface, but not resting on body disk stop.
CAUTION: Actuator stroke stop bolts must be properly adjusted to prevent the valve disc from overstroking. If incorrectly adjusted the valve shaft may be twisted or sheared off.
5. Install valve in line as outlined in Installation section.

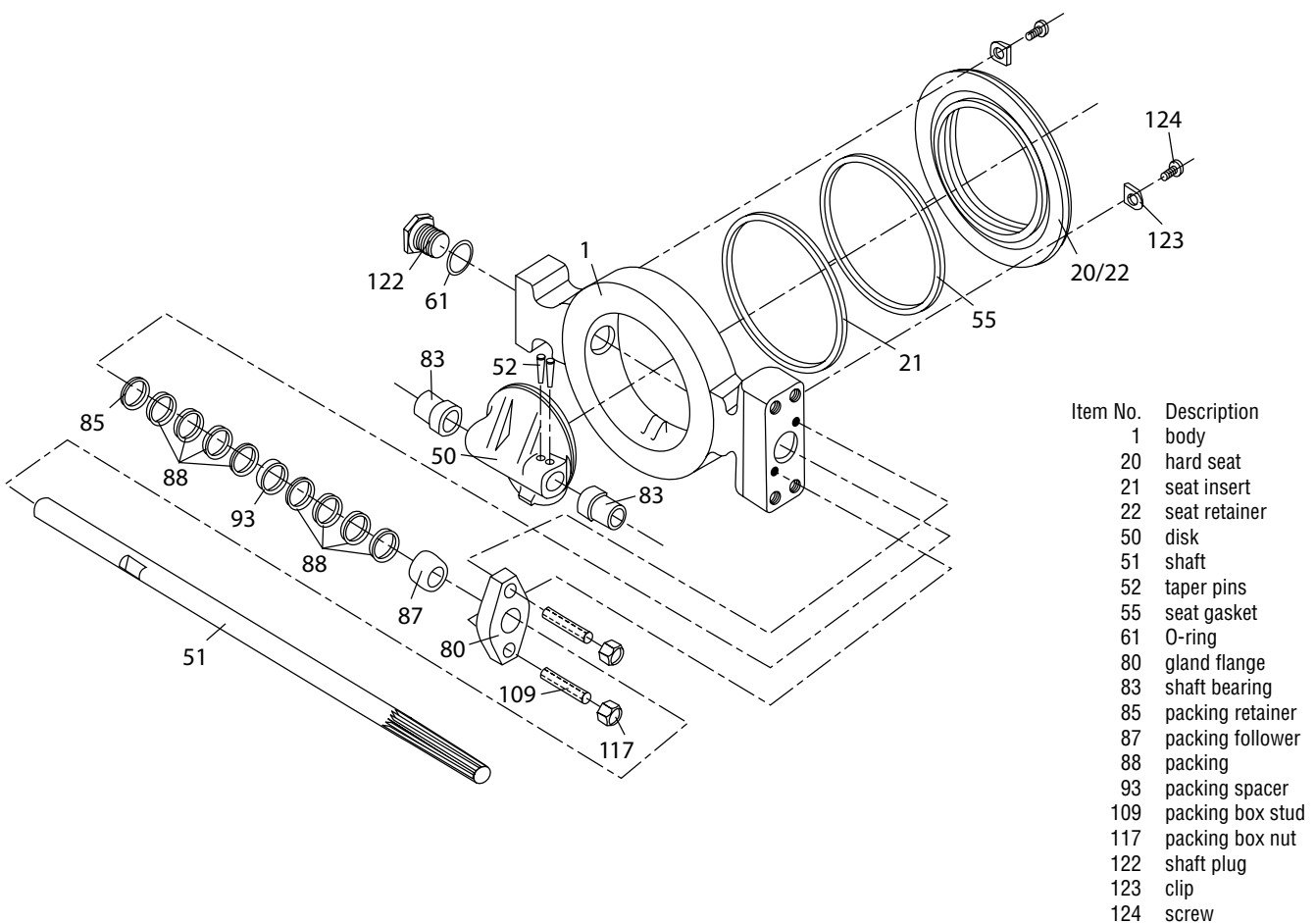

Figure 5: Exploded Body Sub-Assembly

NOTE: Item numbers correspond directly to the bill of material. Refer to it for specific part numbers.

Troubleshooting Valdisk Valves

Failure	Probable Cause	Corrective Action
Valve moves to failure position, excessive air bleeding from transfer case	<ol style="list-style-type: none"> 1. Failure of actuator O-ring 2. Failure of sliding seal assembly 	<ol style="list-style-type: none"> 1. Replace actuator stem O-ring 2. Repair or replace sliding seal assembly
Jerky shaft rotation	<ol style="list-style-type: none"> 1. Overtightened packing 2. Improper adjustment of lever arm on shaft causing arm to contact transfer case 3. Cylinder wall not lubricated 4. Worn piston O-ring allowing piston to gall on cylinder wall 5. Worn actuator stem O-ring causing actuator stem to gall on stem collar 6. Worn (or damaged) shaft bearings, shaft bearings or packing followers 	<ol style="list-style-type: none"> 1. Retighten packing box nuts to slightly over finger-tight 2. Readjust lever arm (see step 1 in the "Remounting Actuator" section) 3. Lubricate cylinder wall with silicone lubricant 4. Replace O-ring; if galling has occurred replace all damaged parts 5. Replace O-ring; if actuator stem is galled replace it 6. Disassemble and inspect parts; replace any worn or damaged parts
Excessive leakage	<ol style="list-style-type: none"> 1. Improper adjustment of external stroke stops 2. Worn or damaged seat 3. Damaged disc seating surface 4. Improper handwheel adjustment acting as limitstop 	<ol style="list-style-type: none"> 1. See "Adjusting External Stroke Stops" section 2. Replace seat 3. Replace disc and shaft 4. Adjust handwheel until disc seats properly
Leakage through line	<ol style="list-style-type: none"> 1. Dirty line gasket surfaces 2. Improper sealing of line flanges 3. Flange or pipe misalignment 	<ol style="list-style-type: none"> 1. Clean gasket surfaces and reinstall valve 2. Tighten line flanges evenly and completely (see Table 1 for proper torque) 3. Clean body bore and stem, replace packing
Leakage through packing box	<ol style="list-style-type: none"> 1. Loose packing box nuts 2. Worn or damaged packing 3. Dirty or corroded packing 	<ol style="list-style-type: none"> 1. Tighten packing box nuts to slightly over finger-tight 2. Replace packing 3. Clean body bore and stem, replace packing
Disc interferes with body	<ol style="list-style-type: none"> 1. Disc installed upside down 2. Worn shaft bearings 	<ol style="list-style-type: none"> 1. Reinstall disc 2. Replace shaft bearings
Disc interferes with line	<ol style="list-style-type: none"> 1. Cement lining or heavy schedule pipe 	<ol style="list-style-type: none"> 1. Modify line to allow proper disc clearance
Valve slams, won't open, or causes severe water hammer	<ol style="list-style-type: none"> 1. Improper valve installation 	<ol style="list-style-type: none"> 1. See step 2 in "Installation" section and correct flow direction
Shaft rotates, disc remains open or closed	<ol style="list-style-type: none"> 1. Missing or broken taper pins 2. Broken shaft 	<ol style="list-style-type: none"> 1. Replace taper pins 2. Replace shaft, make sure shaft is not overstressing on external stroke stop
Actuator operates, shaft does not rotate	<ol style="list-style-type: none"> 1. Broken internal actuator parts 	<ol style="list-style-type: none"> 1. Refer to appropriate actuator Maintenance Instructions

Flowserve Corporation has established industry leadership in the design and manufacture of its products. When properly selected, this Flowserve product is designed to perform its intended function safely during its useful life. However, the purchaser or user of Flowserve products should be aware that Flowserve products might be used in numerous applications under a wide variety of industrial service conditions. Although Flowserve can (and often does) provide general guidelines, it cannot provide specific data and warnings for all possible applications. The purchaser/user must therefore assume the ultimate responsibility for the proper sizing and selection, installation, operation and maintenance of Flowserve products. The purchaser/user should read and understand the Installation Operation Maintenance (IOM) instructions included with the product, and train its employees and contractors in the safe use of Flowserve products in connection with the specific application.

While the information and specifications presented in this literature are believed to be accurate, they are supplied for informative purposes only and should not be considered certified or as a guarantee of satisfactory results by reliance thereon. Nothing contained herein is to be construed as a warranty or guarantee, express or implied, regarding any matter with respect to this product. Because Flowserve is continually improving and upgrading its product design, the specifications, dimensions and information contained herein are subject to change without notice. Should any question arise concerning these provisions, the purchaser/user should contact Flowserve Corporation at any of its worldwide operations or offices.

For more information contact:

For more information about Flowserve and its products,

contact www.flowserve.com or call USA 972 443 6500

Manufacturing Facilities

1350 N. Mt. Springs Prkwy.
Springville, UT 84663
Phone 801 489 8611
Facsimile 801 489 3719

45141 Essen, Germany
Telephone (49) 2 01 89 19 5
Facsimile (49) 2 01 891 9600

1300 Parkway View Drive
Pittsburgh, PA 15205 USA
Telephone 412 787 8803
Facsimile 412 787 1944

All'oe du Quartz 1
CH-2300 La Chaux-de-Fonds
Switzerland
Telephone (41) 32 925 9700
Facsimile (41) 32 926 5422

Manderscheidstr. 19

5114 Railroad Street
Deer Park, TX 77536 USA
Telephone 281 479 9500
Facsimile 281 479 8511

104 Chelsea Parkway
Boothwyn, PA 19061 USA
Telephone 610 497 8600
Facsimile 610 497 6680

Quick Response Centers

